

INFO-TECTURE

Information Architecture by DATASCAPE

CHEOL-HEE PARK

Selected Works

WORKS VOLUME

Profile

- Introduction

Urban Lung

- Graduation Exhibition Grand Prize

SHINYIMUN ; Connected Neighborhood

- 2019 KRA Awards Grand Prize

2035 Modular Cloud Platform

- 2020 SMA Competition Encouragement Award

Grown Scape

- Detailed Drawing Study Project

Alleyway Theater

- Detailed Drawing Study Project

BIM Challenge

- LotteTower Information Modeling & Visualization



International Workshop Review

CAREER

EDUCATION

Dongil Technical High School (Department of Digital Electronics)

Korea National University of Transportation (Department of Architecture)

EXPERIENCE

2017 — 2019

Korea National University of Transportation, DART Laboratory Student **Researcher**

2018 - 12 - 06

Chungbuk Office of Education, Shinmi Middle School Architecture Program **Tutor**

2018 - 12 - 19 — 2018 - 12 - 23

Chiangmai University, International Urban Regeneration Workshop Student **Researcher**

2019 - 04 - 15 — 2019 - 04 - 26

KNU, Rhino Grasshopper & V-ray Lecture Trainee

2019 - 06 - 24 — 2019 - 07 - 19

SANGJI Architects Seoul Branch, S.E.A Architects **Intern**

2020 - 08 - 24 — 2020 - 08 - 28

SAMOO Architects, Samoo Design Workshop **Completion**

2021 - 01 - 04 — 2021 - 01 - 19

GOOGLE & Opentutorials, Machine Learning & Deep Learning School **Completion**

2020 - 12 - 28 — 2021 - 03 - 19

Ministry of Land & Transport KICTE, BIM Professional Training Course **Completion**

2021 - 02 - 15 — 2021 - 03 - 19

ARCHIOFT, BIM Expert Certification Course / BIM Specialist Course **Completion**

2021 - 05 - 03 — 2021 - 06 - 30

ENCORE Playdata, Data - Driven Artificial Intelligence Service Developer Course

AWARDS



2019 Korea Railroad Corporation, Korea Railroad Awards **Grand Prize (2nd)**

2019 KICA, Next Generation Cultural Space Competition **Special Selection**

2020 Korea National University of Transportation, Graduation Exhibition **Grand Prize (3rd)**

2020 Korean Society of Architecture, Academic Conference Bachelor Thesis **Honor - Award**

2020 Korea Steel Association, Steel Modular Architecture Competition **Encouragement Award**

CONTACT

Information

NAME	CHEOL-HEE PARK	ADDRESS	33, Dongil - Ro 58 - gil,
PHONE	(+82) 10 - 9248 - 2485		Gwangjin-gu, Seoul,
E-MAIL	park112368@gmail.com		Republic of Korea

PROFICIENCY

Architectural Software & ETC

SketchUp 2019	██████████	V - Ray	██████████
Revit 2019	██████████	Twinmotion	██████████
ArchiCAD 2019	██████████	Photoshop CS6	██████████
AutoCAD 2018	██████████	Illustrator CS6	██████████
Rhinoceros 7.0	██████████	MS Office	██████████
Grasshopper	██████████	Python Library	██████████

Urban Lung

- Seoul Carbon Neutral Zone ; Carbon Exchange



Individual Project

GREEN CORRIDOR

CARBON NEUTRAL ZONE

Climate change disasters such as forest fires in Australia, glaciers and rising sea levels are due to carbon dioxide emissions. Cities account for 70% of the total amount of carbon already emitted, and large amounts of carbon dioxide emitted are causing heat island phenomena and fine dust, and are changing the city's landscape. Therefore, the architectural program for carbon neutrality must be carried out on an urban level and have an urban scale.

Graduation Project

Synopsis

- World Issue ; Climate Change

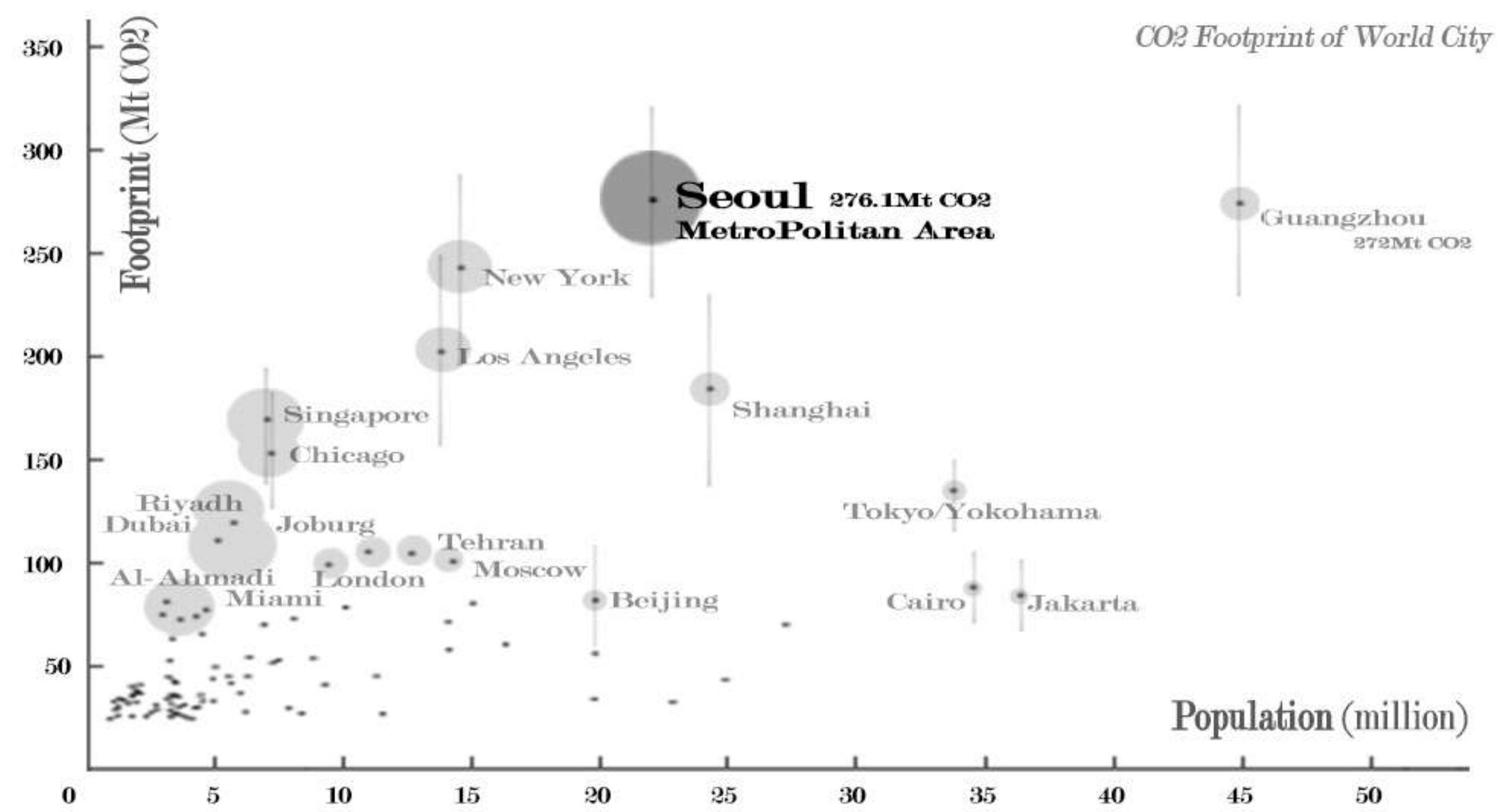

Emission City ; Surface temperatures rose after the Industrial Revolution. Global warming is largely due to the increase in greenhouse gases caused by human activity. According to the IPCC report, cities generate most of their carbon emissions, with 54% of the world's population living in cities. If you look at the world's carbon dioxide emissions, you can see that Seoul is the largest emitter, and the top 100 cities account for 18% of the total emissions.

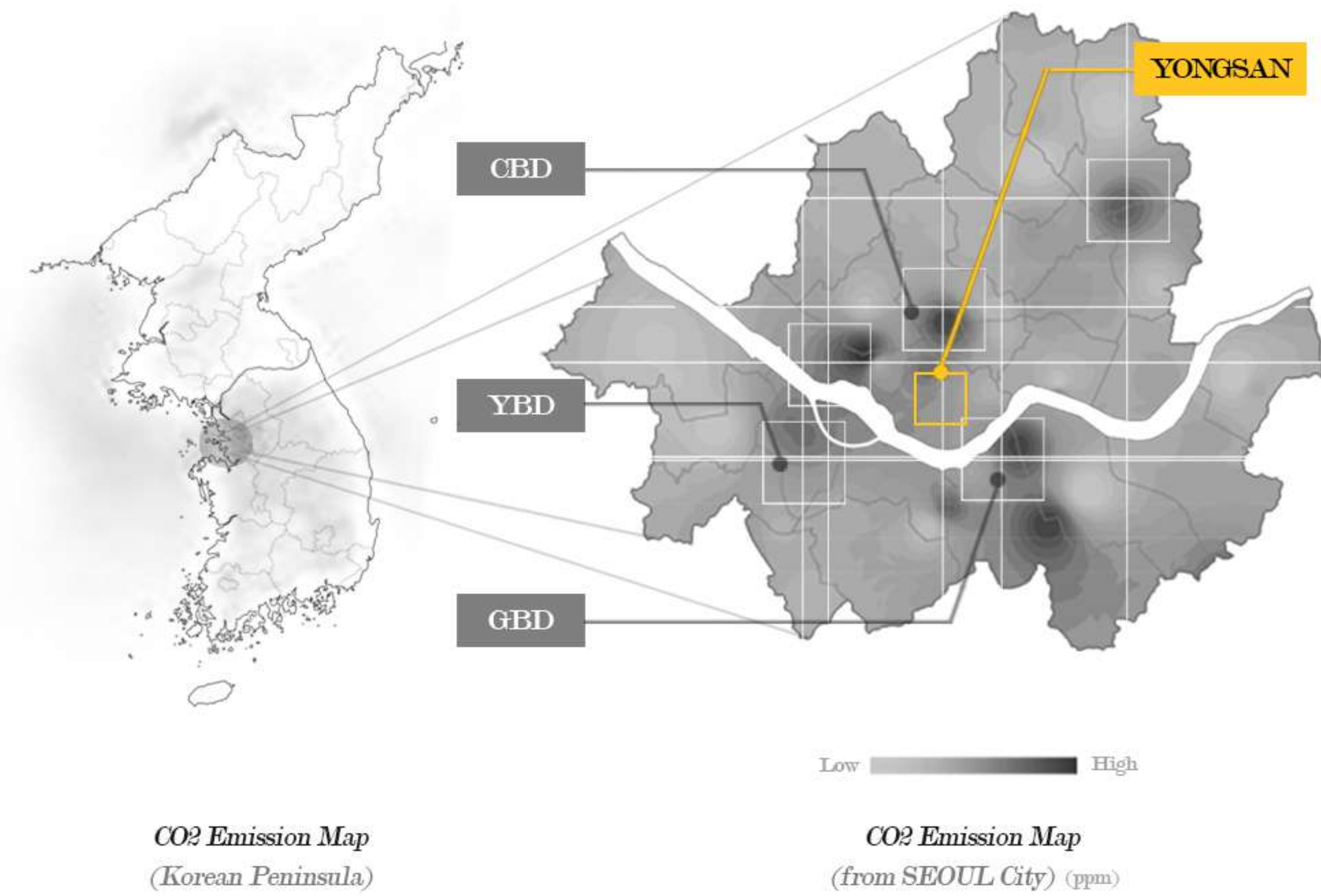

Emission of Business District ; Carbon dioxide emitted causes heat island phenomenon and fine dust following climate change. Looking at the Seoul Metropolitan Government's carbon dioxide emission map, you can see that the three business districts emit the most. Since YONGSAN is located in the heart of three business districts, it has the potential to respond to carbon dioxide emissions in all directions.

Currently, the U.S. military base in Yongsan is considering withdrawing, so large-scale empty land will be created in the near future. Empty land shall be designated as a carbon dioxide neutral zone and a large forest shall be created to increase the area of carbon sinks.

Site Selection

- YONGSAN as a Carbon Absorber

YONGSAN Context Analysis

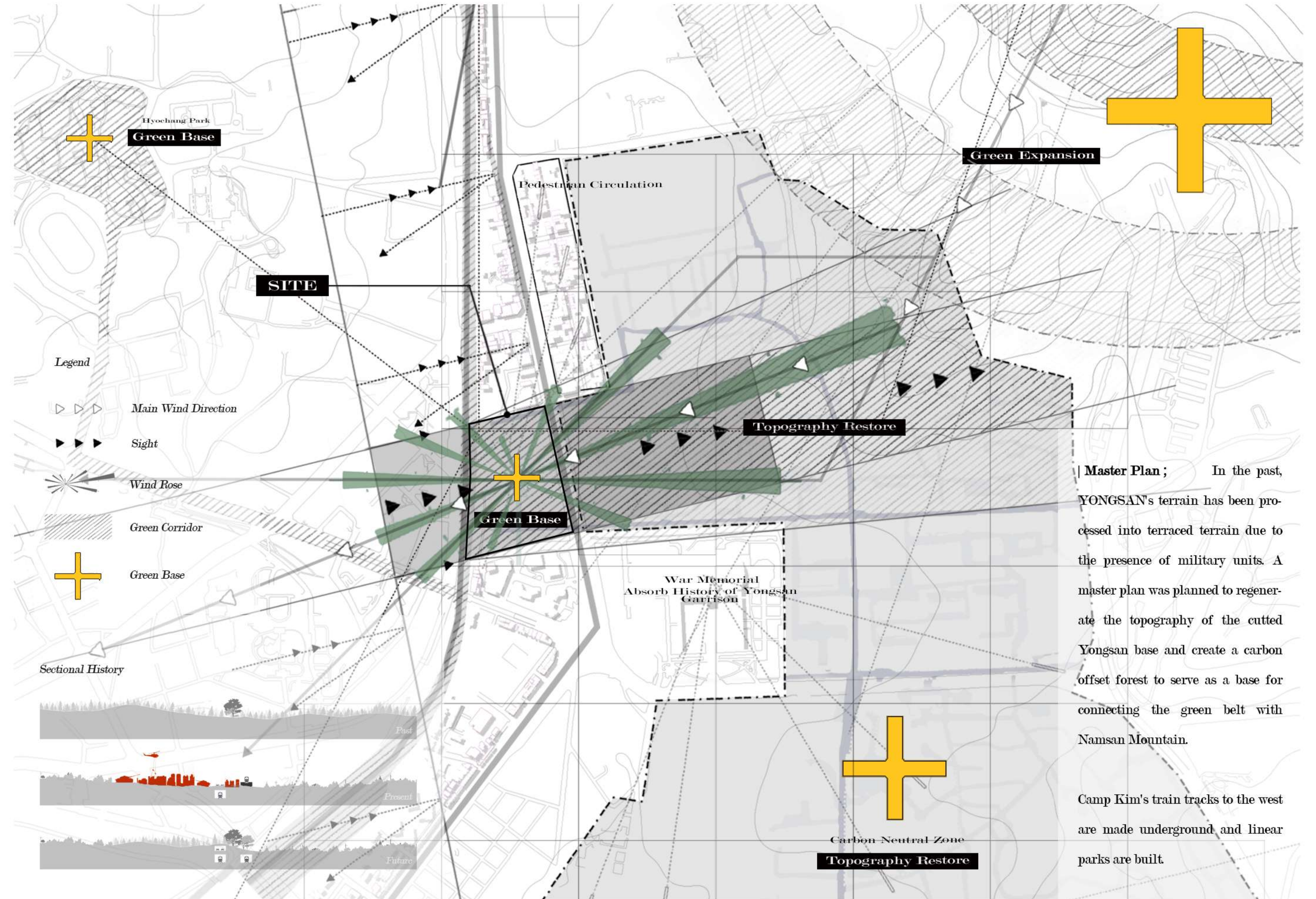

Master Plan ; In the past, YONGSAN's terrain has been processed into terraced terrain due to the presence of military units. A master plan was planned to regenerate the topography of the cutted Yongsan base and create a carbon offset forest to serve as a base for connecting the green belt with Namsan Mountain.

Camp Kim's train tracks to the west are made underground and linear parks are built

Design Process

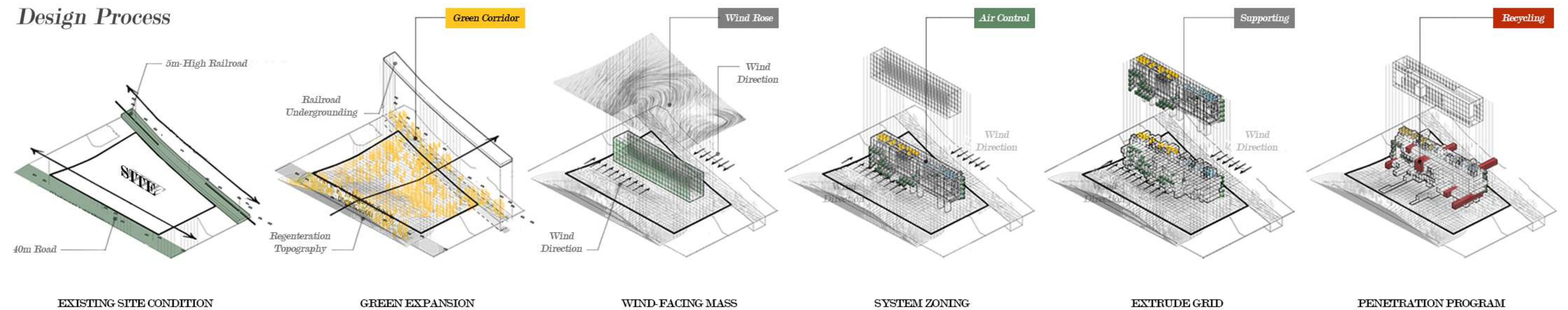

Carbon Absorber

- Carbon Dioxide Absorption

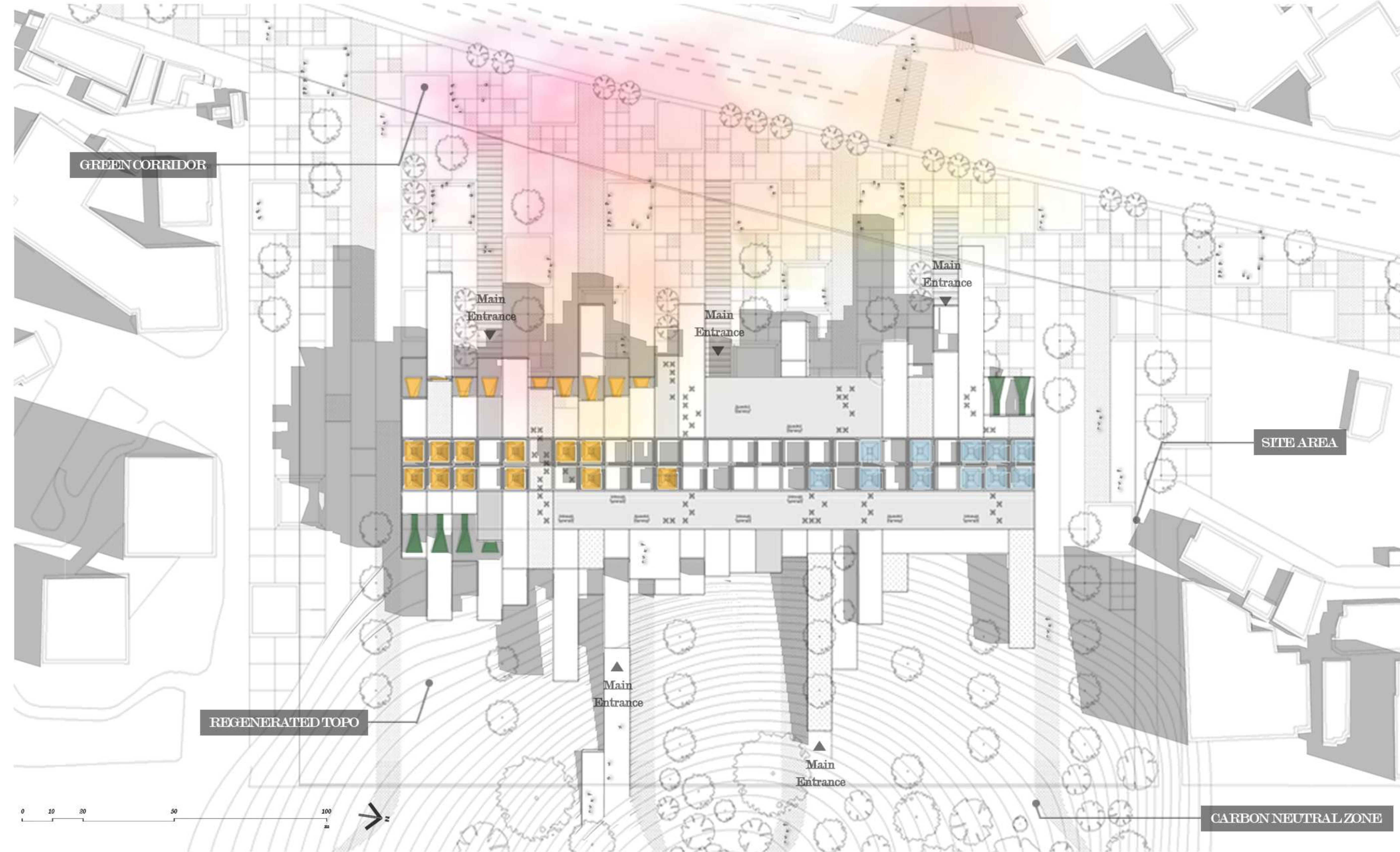

Site Plan

Programming

- CO2 Emission Sources Analysis

Carbon Emission Sources

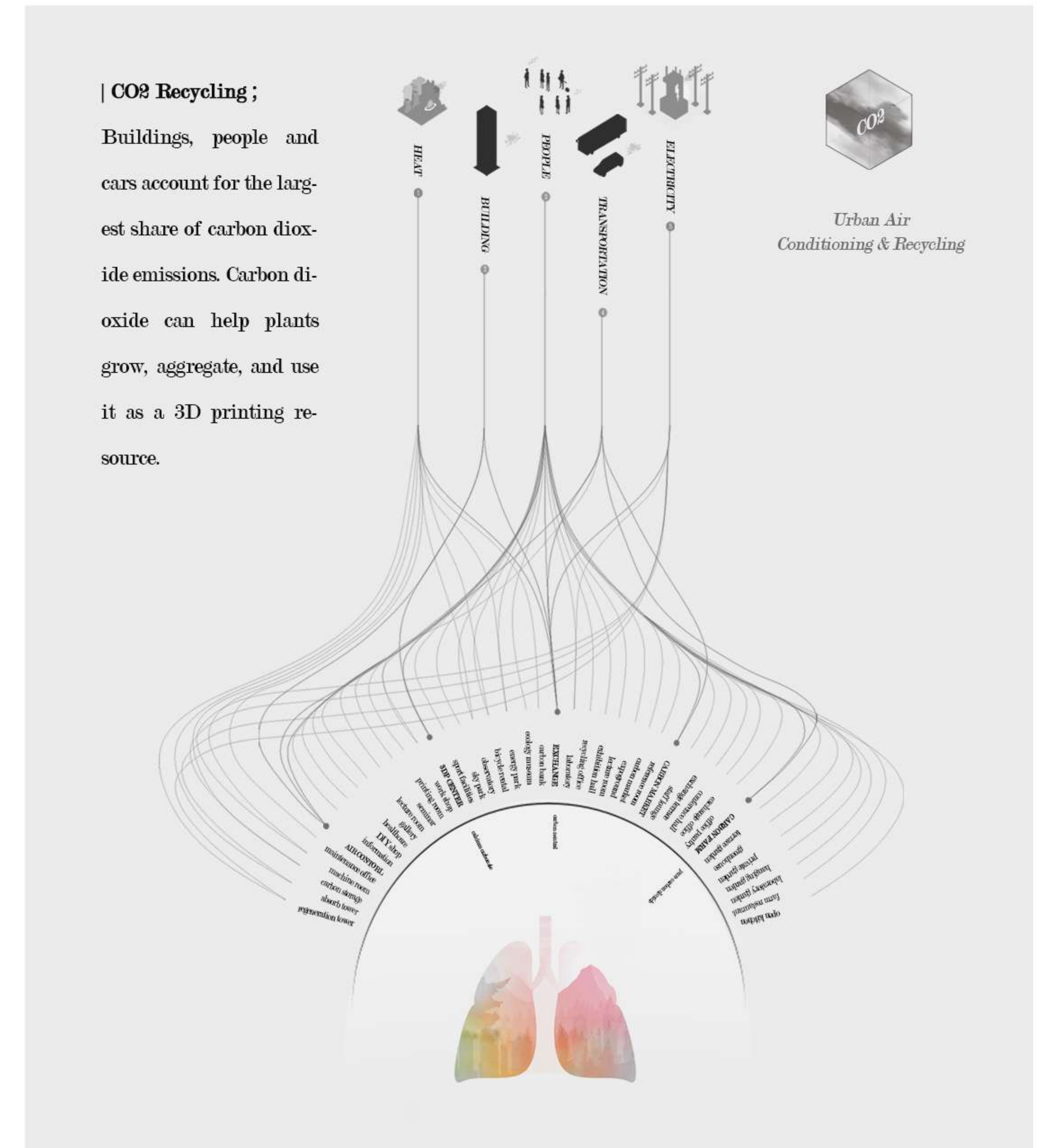

| CO2 Data ; Carbon exchange absorb carbon dioxide and provide fresh air. To build a building that absorbs carbon dioxide, convert the density of carbon dioxide to a numerical value, make it into a module, and use it as a unit of spatial composition.

Carbon dioxide is greatly affected by wind because it exists in the atmosphere in the form of gases. Since the slopes of Namsa and Cheongpa-dong in Yongsan-gu are connected to the site, the wind blows strongly along the flow of the terrain.

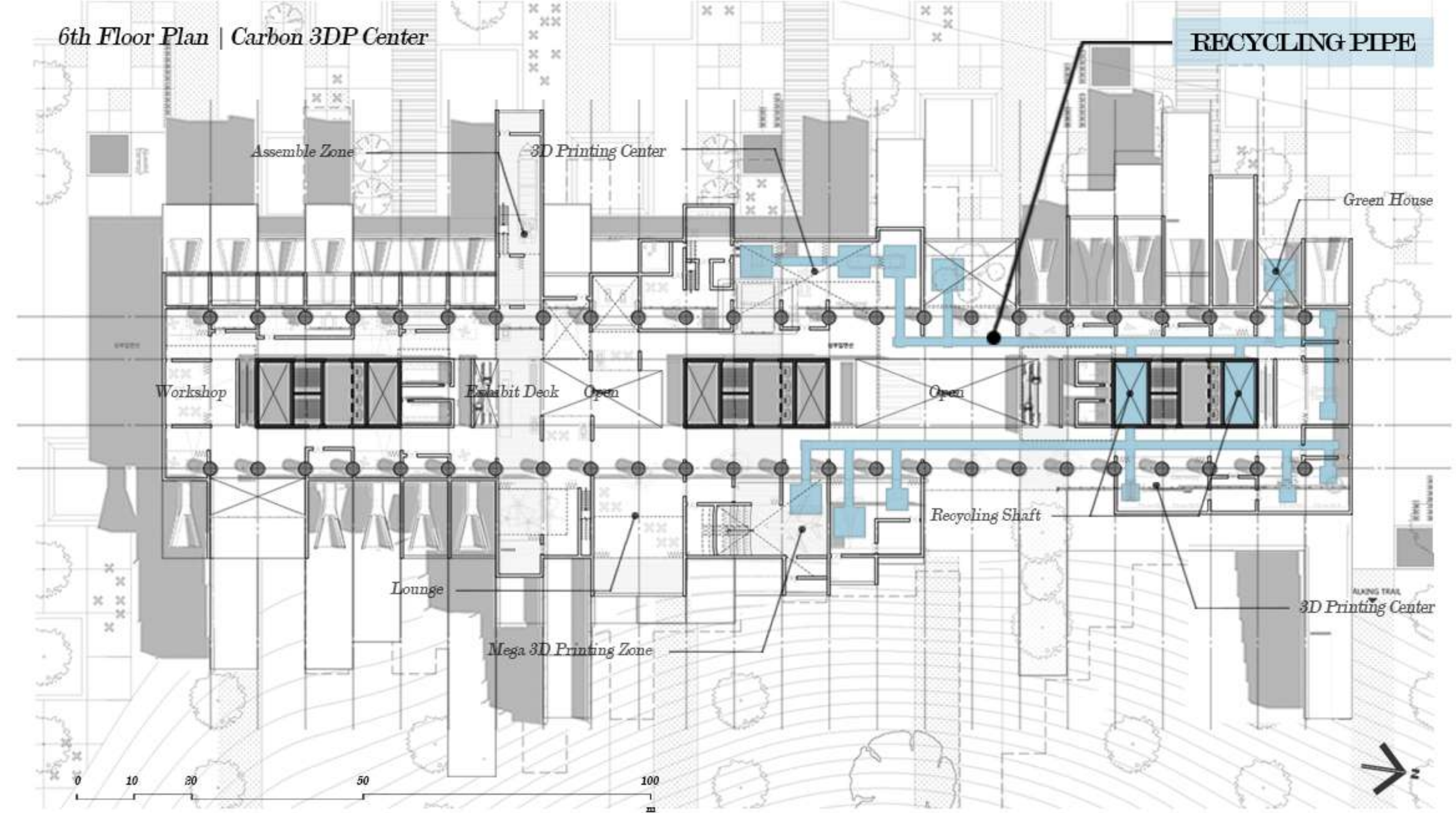
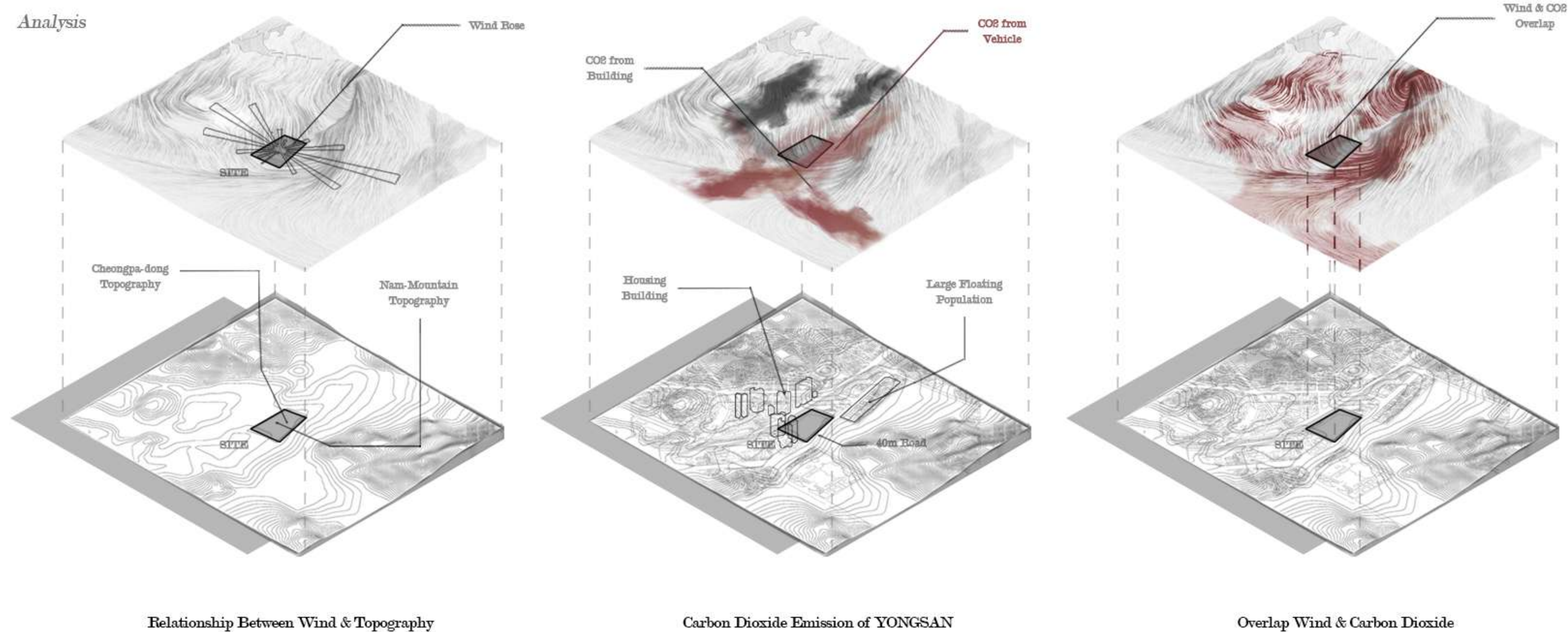

Capture System

- CO₂ Capture & Separation

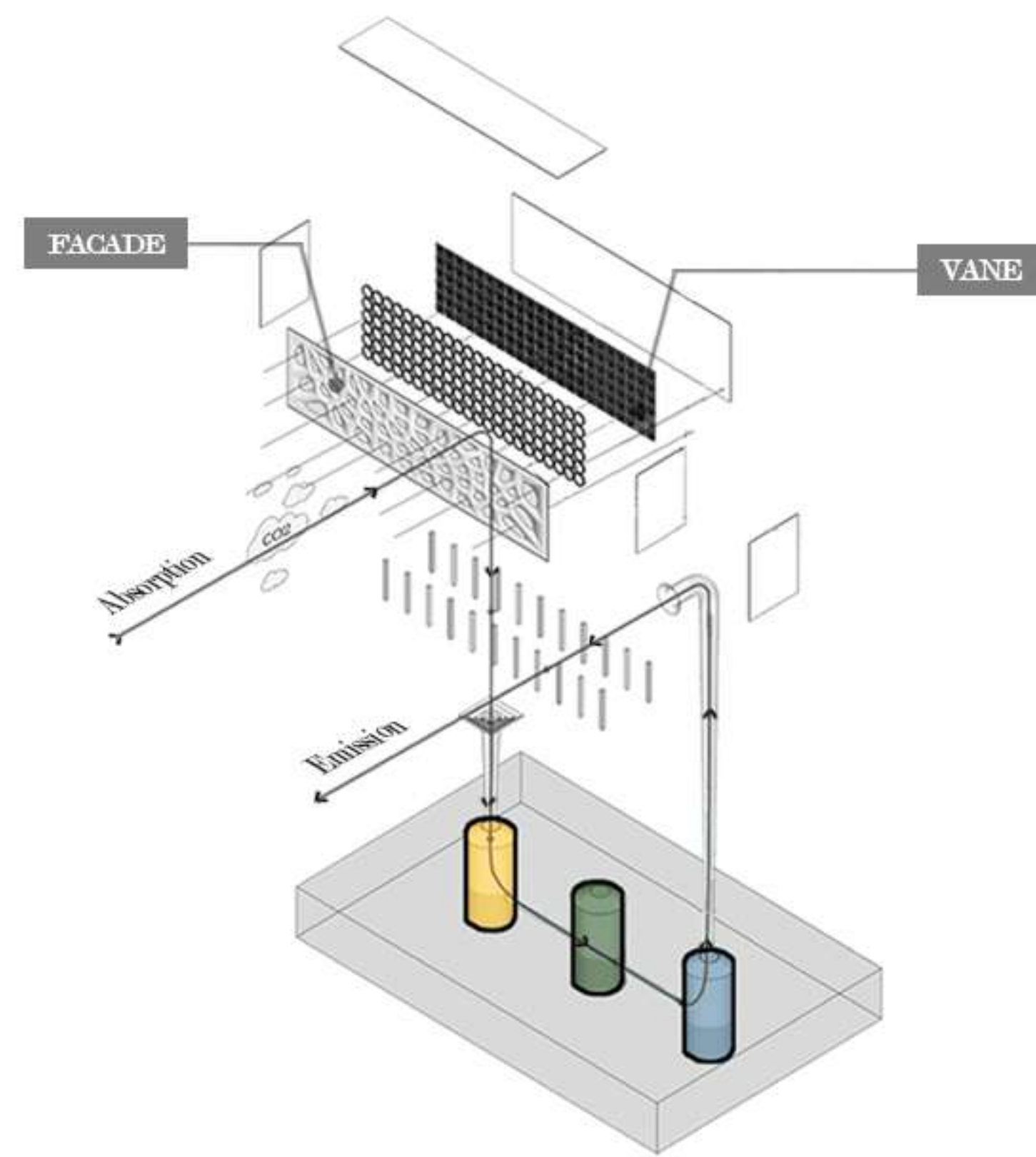

Direct Air Capture System Flow

| **DAC System** ; The DAC system is a system that separates carbon dioxide from nitrogen by capturing the atmosphere, including carbon dioxide.

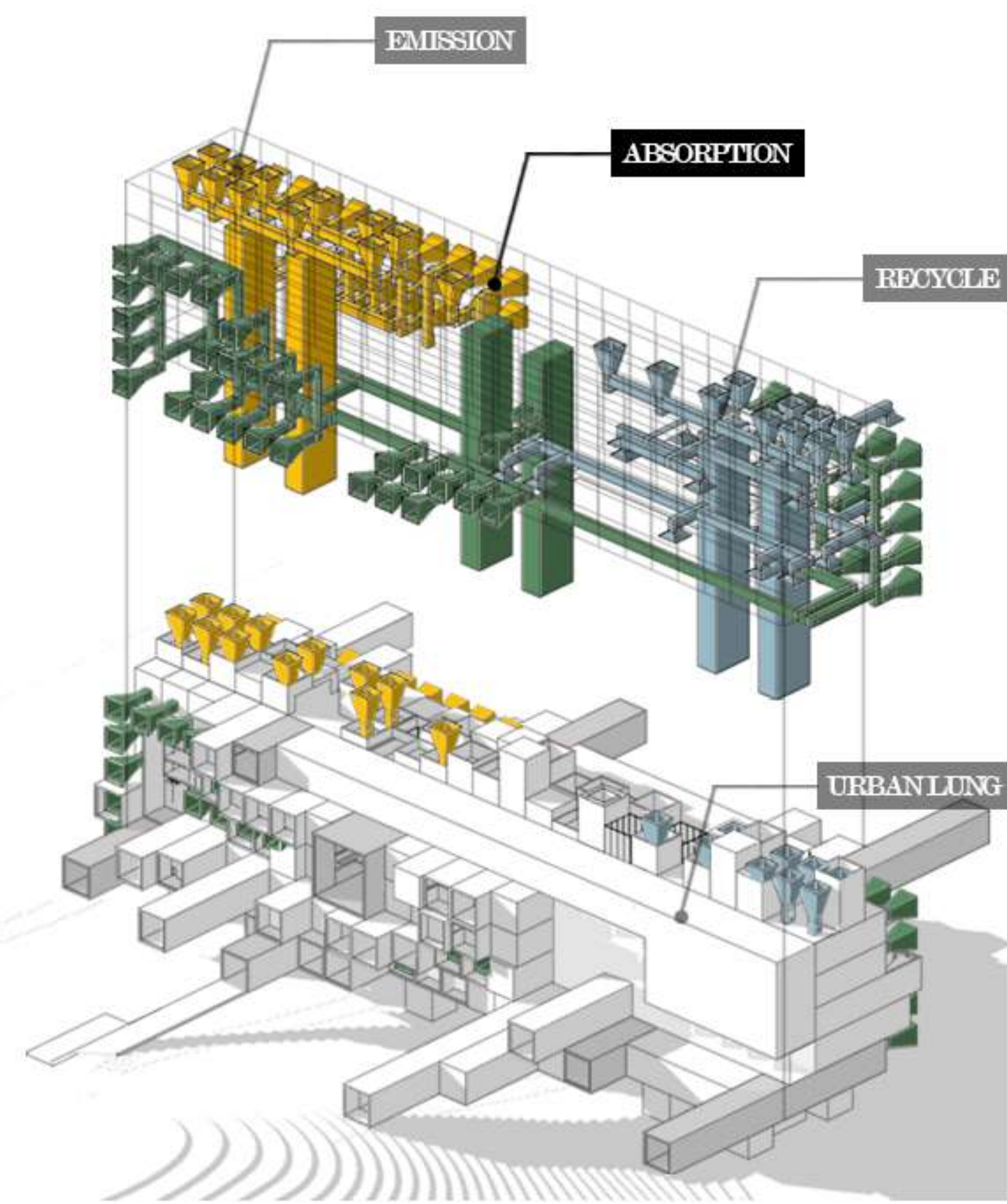

Building System Drawing

| **System Zoning** ; By transforming the above DAC system, the system was zoned by the nature of absorption, emission, and reuse. It integrates central core and Air Shaft to optimize the flow of system pipes. After that, insert the program.

System Drawing

- CO₂ Recycling

| **Sectional Zoning** ; The DAC system separates carbon dioxide and nitrogen from the captured atmosphere through the kirsol. And the separated carbon dioxide is recycled.

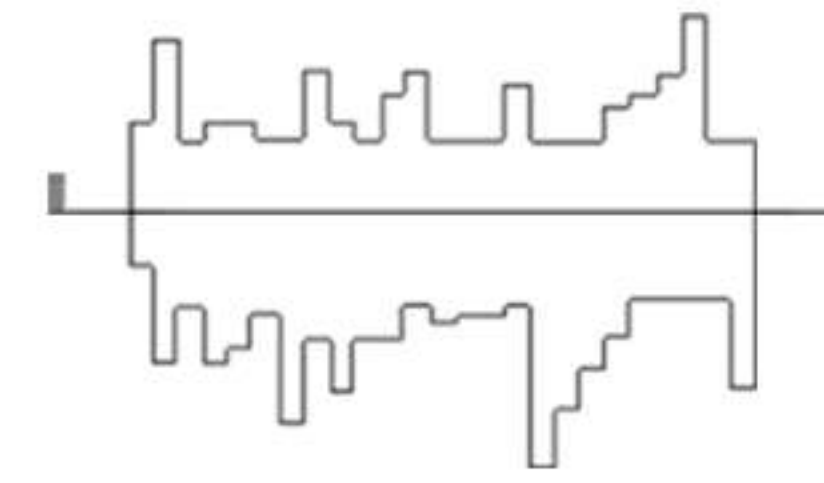

CO₂ Carbon Dioxide K Kirsol N₂ Nitrogen

System Flow-Chart

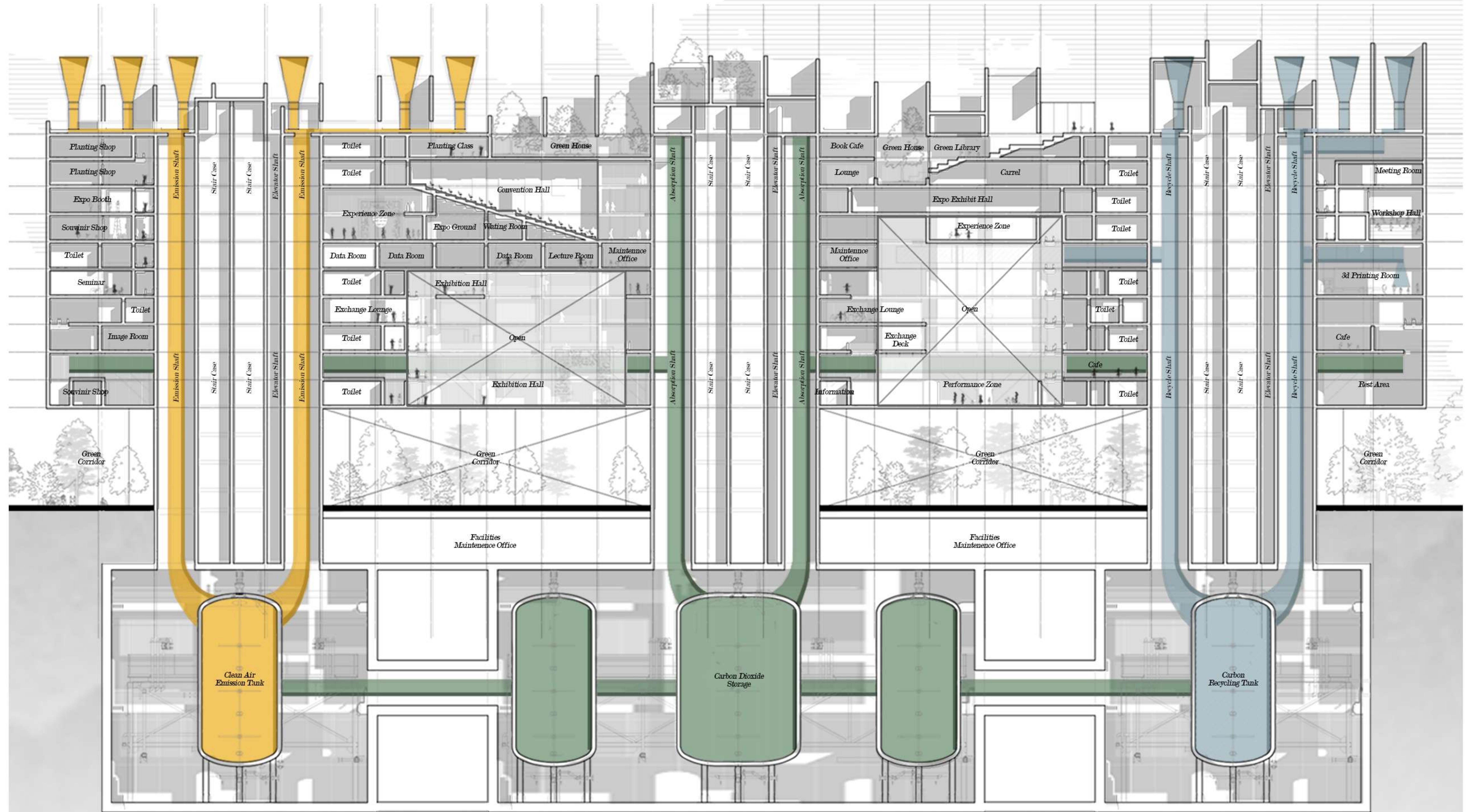
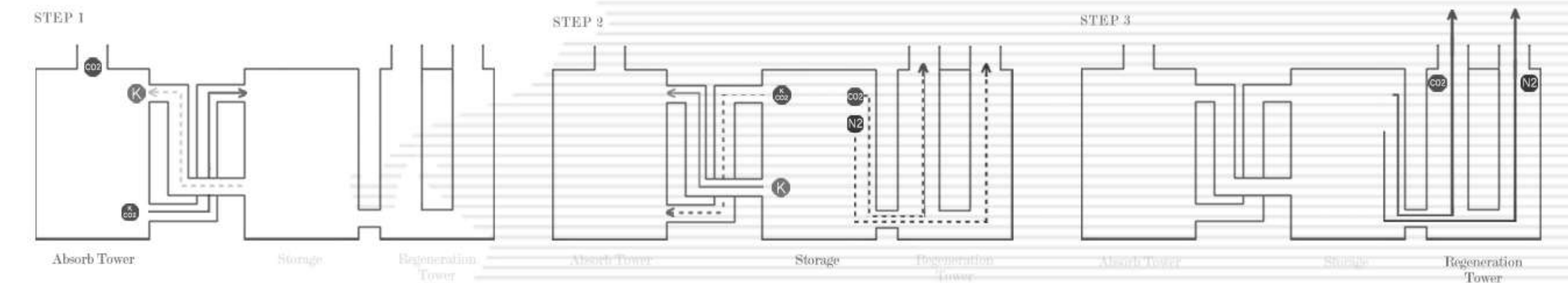

Section Plan

SHINYIMUN; Connected Neighborhood

— Creating a Pedestrian-oriented Neighborhood for YIMUN-Dong



Team Project

- Analysis
- Main Idea
- Diagram
- Drawing
- Modeling
- Visualization

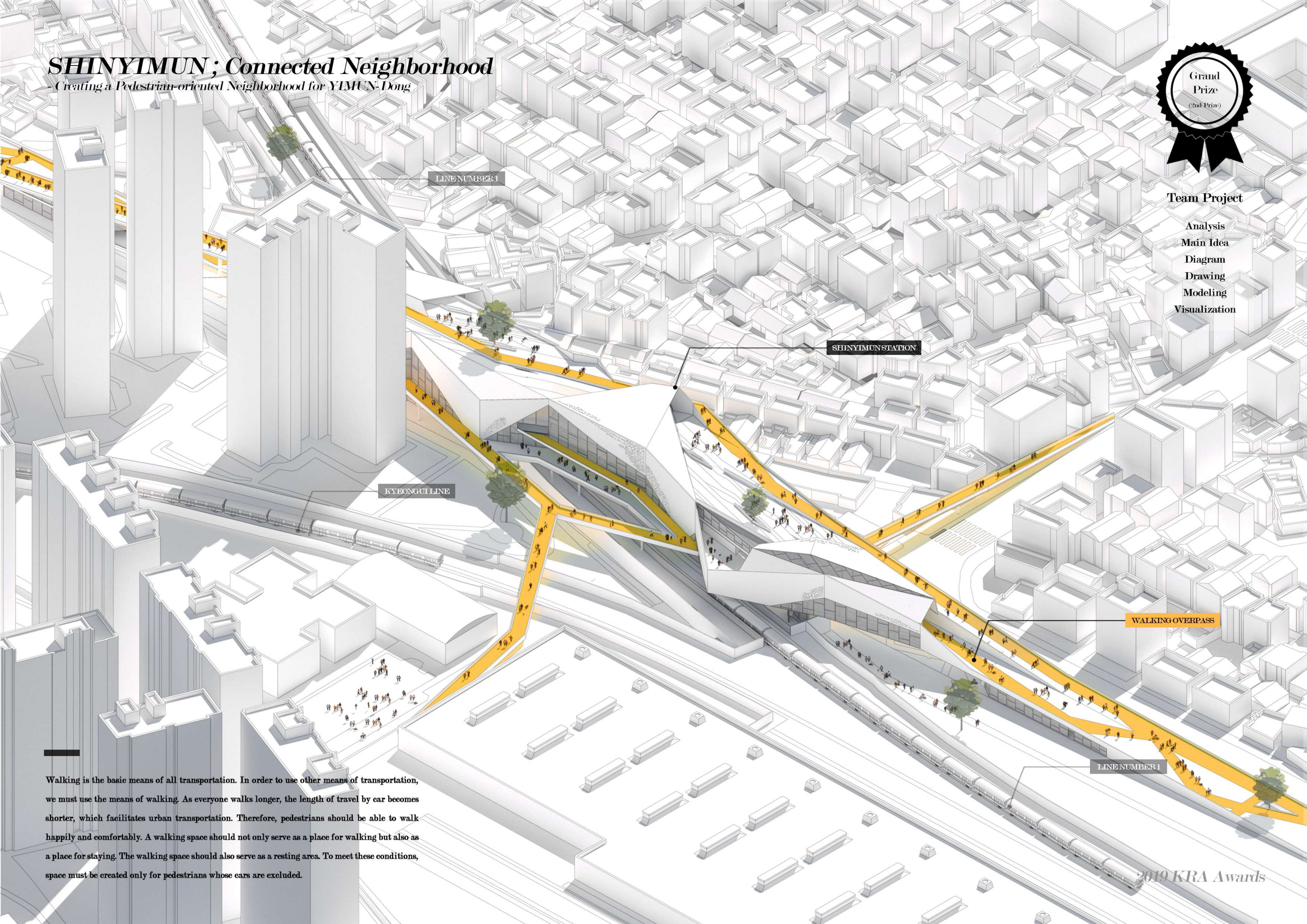

LINE NUMBER 1

SHINYIMUN STATION

KYBONGU LINE

WALKING OVERPASS

LINE NUMBER 1

Walking is the basic means of all transportation. In order to use other means of transportation, we must use the means of walking. As everyone walks longer, the length of travel by car becomes shorter, which facilitates urban transportation. Therefore, pedestrians should be able to walk happily and comfortably. A walking space should not only serve as a place for walking but also as a place for staying. The walking space should also serve as a resting area. To meet these conditions, space must be created only for pedestrians whose cars are excluded.

Synopsis

- Stacked Station & Overpass

| Yimun-Overpass & Station ; As the railway line No. 1 was built in Yimun-dong, Dongdaemun-gu, Seoul, the living area of the east and west was separated based on the railway. Since then, vehicle traffic has been eased by the creation of an overpass across the railway, but pedestrians' traffic has not been resolved, but a passive walking environment has been created with the creation of Shinmun Station. However, pedestrians are still not free to move east-west.

Yimun-Dong Timeline

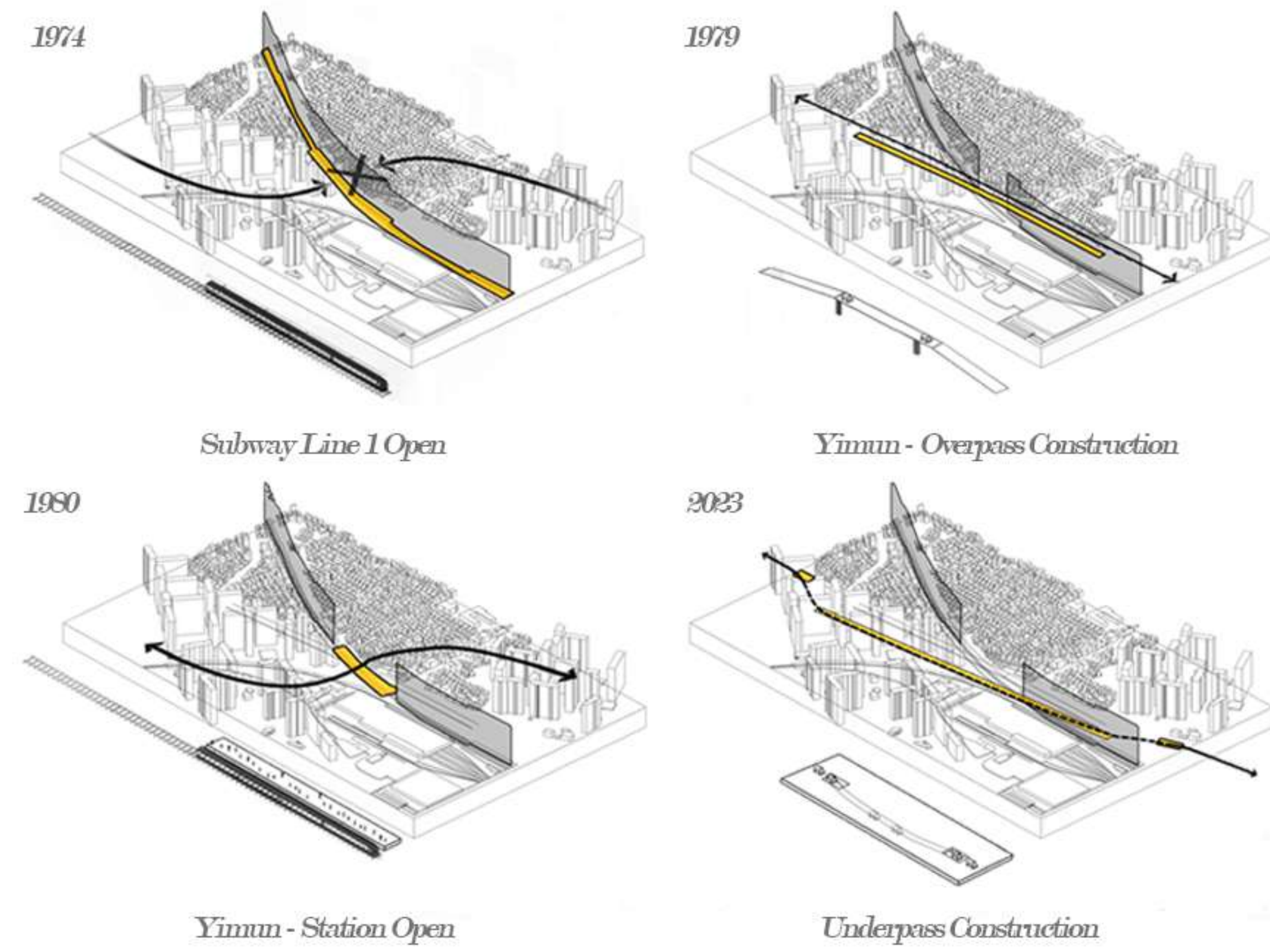

| Inactive Connection ; Yimun-Overpass, which has been in place for 40 years, is old and is under review for demolition or undergrounding. Therefore, the overpass will be converted into an underground road and made into a pedestrian bridge. Shinyimun Station between the overpass and the railway line 1 was removed except for the platform. The overpass will be a pedestrian-only route, and it will be a path for the Shinyimun Station building itself. The diverse walking environment in Imun-dong will increase walking distance, making it easier to move between neighborhoods.

2023 Yimun-Dong Section

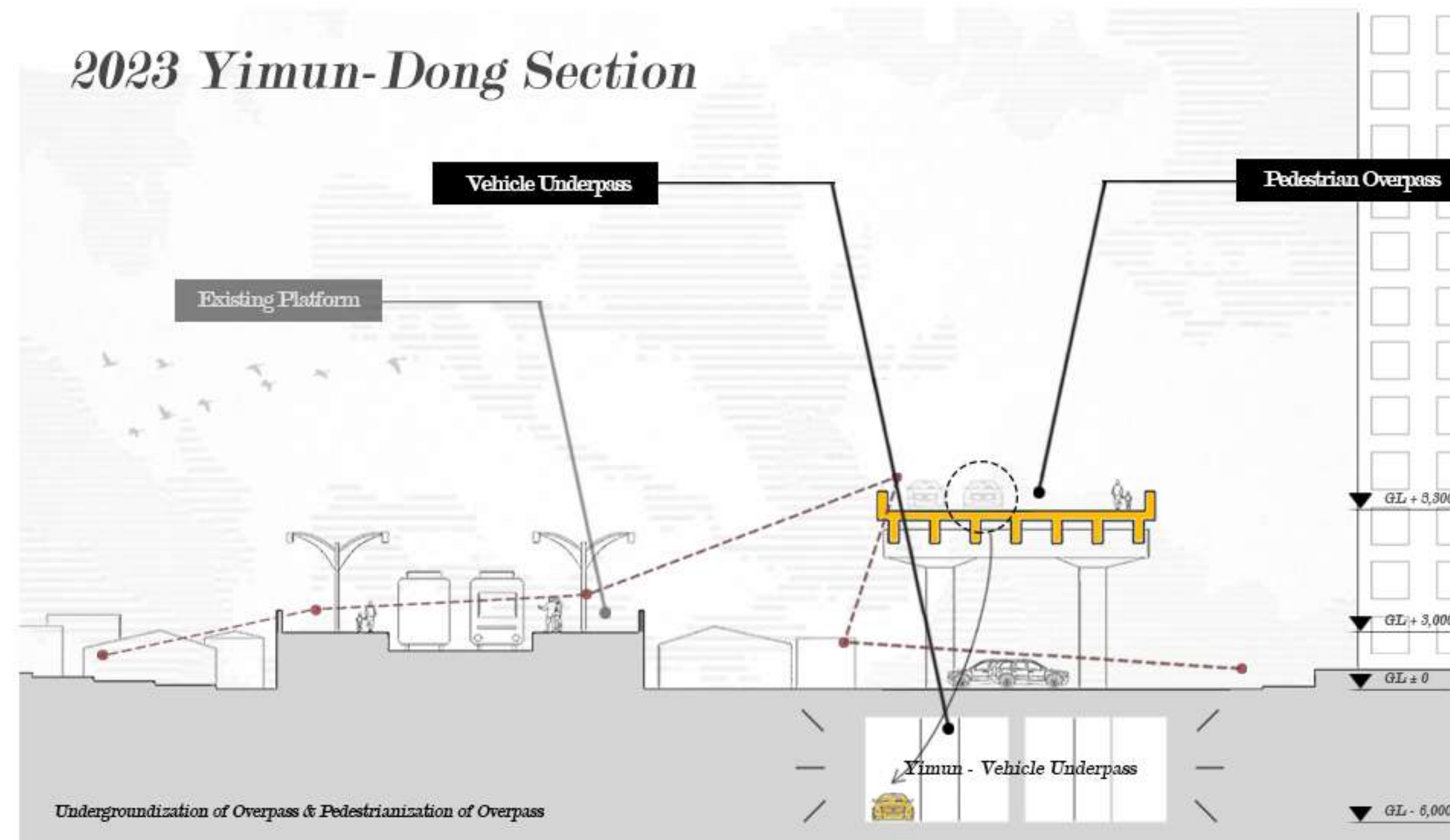

Possibility of Shinyimun

- Yimun - Dong Figure & Ground

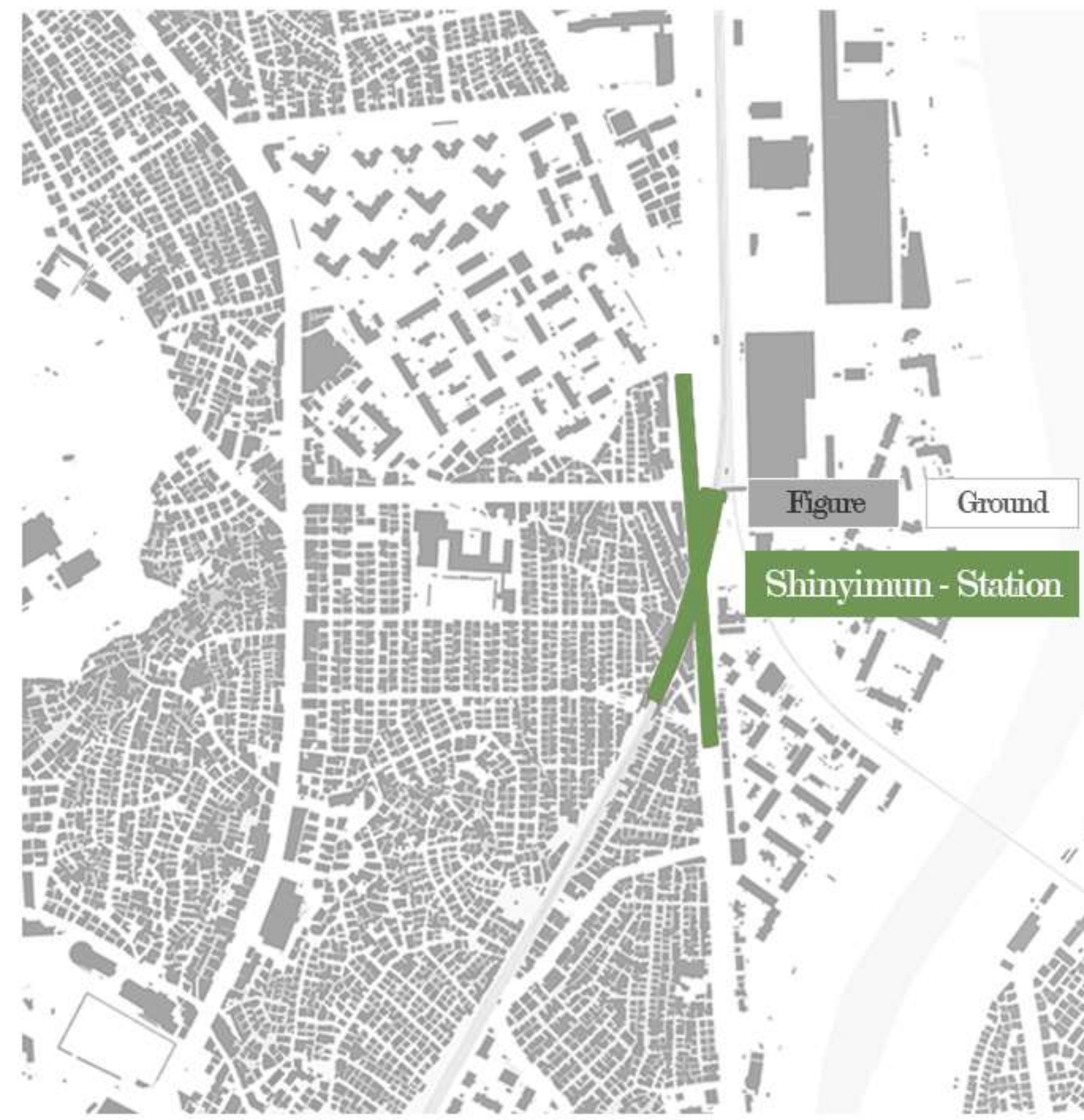

Green Area per Person of SEOUL

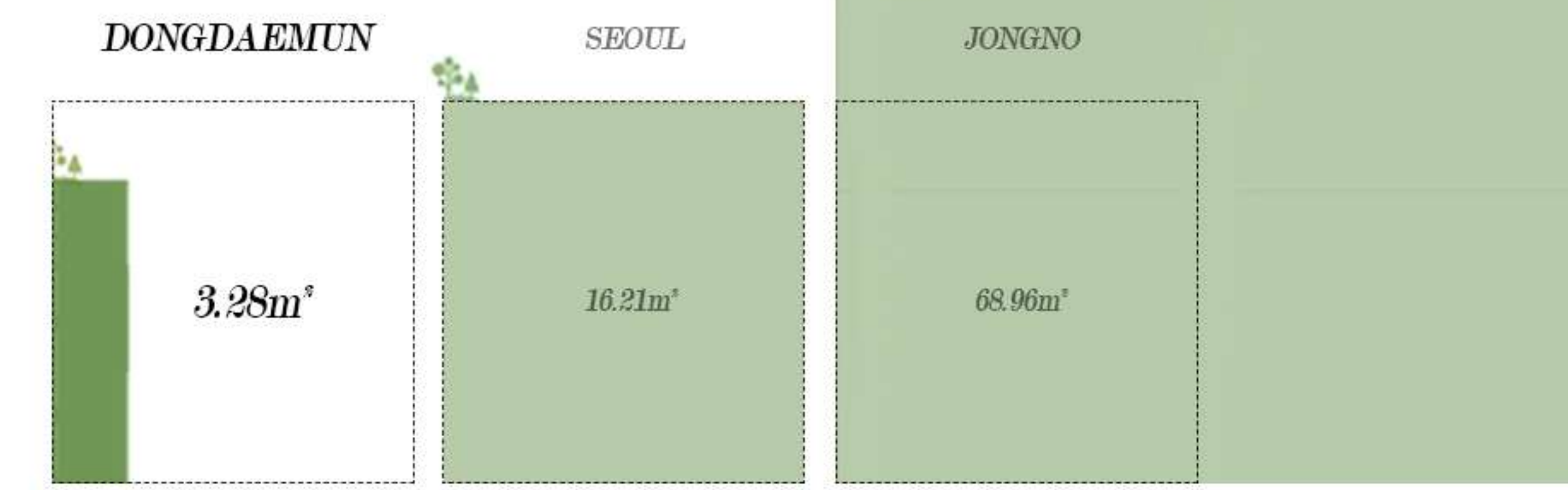

Design Elements

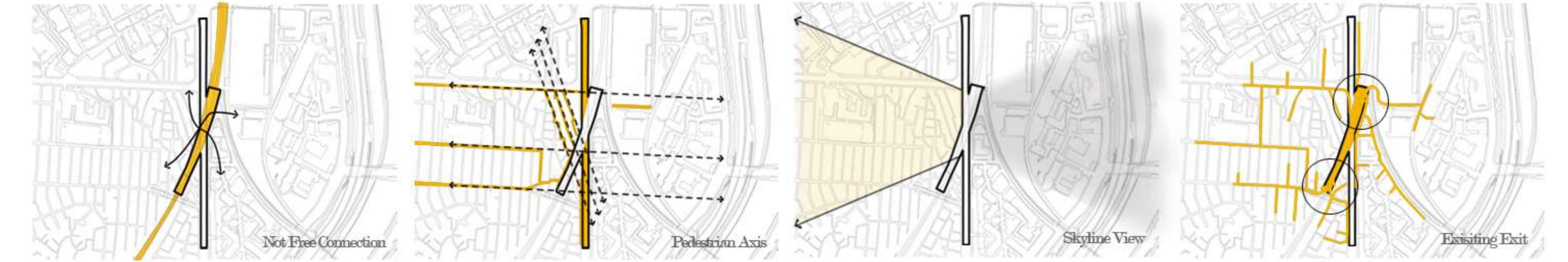

Green Area of Yimun - Dong

| a Static City ; Dongdaemun-gu is ranked 25th out of 25 districts in Seoul, accounting for only 20 percent of the city's per capita park area. Imun-dong, which belongs to the old city center of Seoul, has no land that can be turned into a park because the majority of the area has been developed. Therefore, it would be a more sustainable way to create a park by combining public facilities.

Design Process



New Promenade

- New Promenade in the City for Pedestrian

| **a Static City** ; The existing overpass will become a walking path and function as a walking path and a waiting room for Shinyimun Station. The newly constructed walkways provide a slow experience of every corner of the building. The upper opening located in the center of the waiting room enables visual contact between vertically stacked programs. This increased psychological and physical access to upper programs.

The ramp section of the overpass has been created as a park and playground. In addition, a barrier-free design can be implemented to increase the reverse utilization rate of disabled people due to the low slope of the overpass.

Station for Flaneur

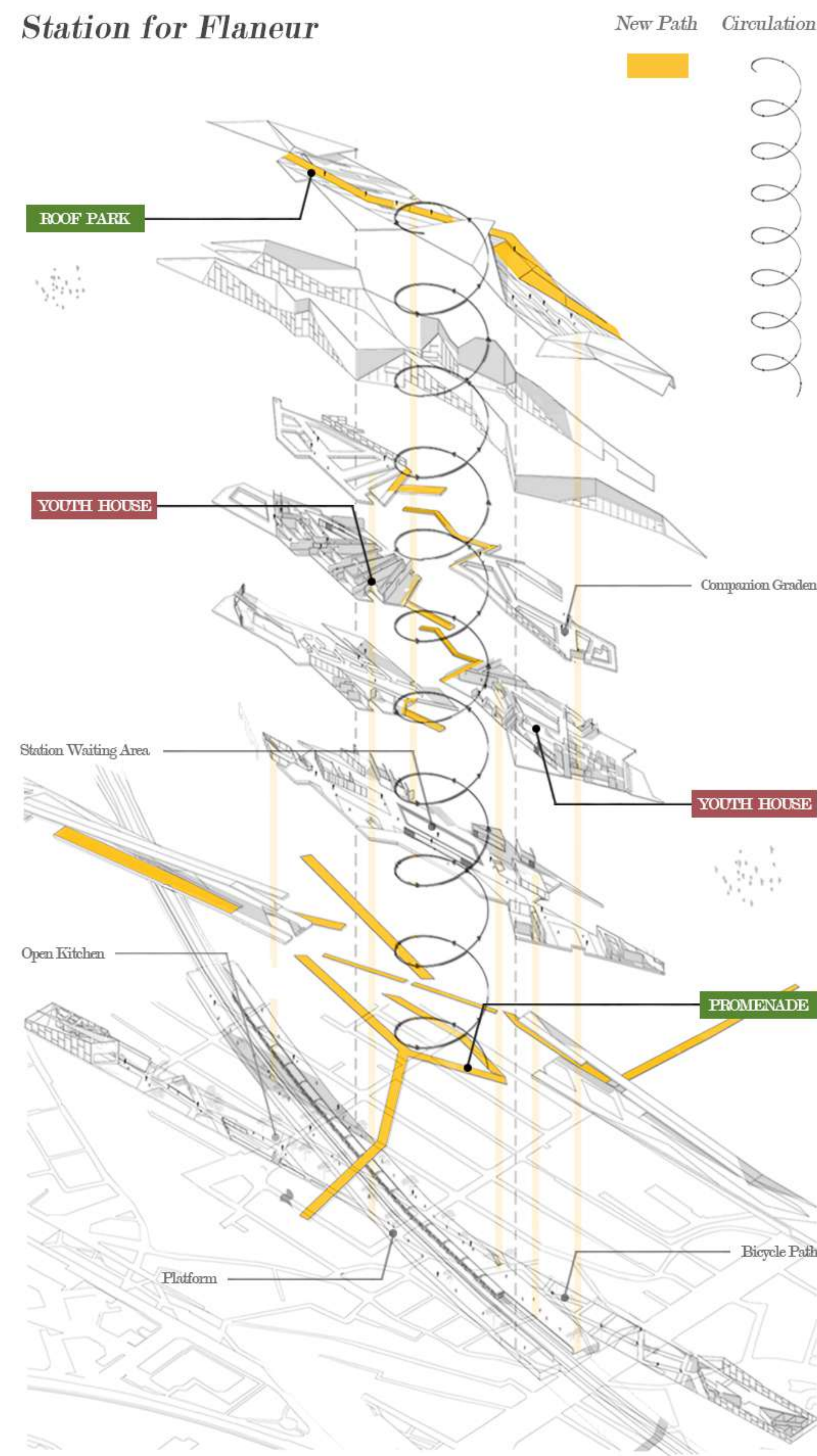

Program Reorganization

- Pedestrian City

Site Plan

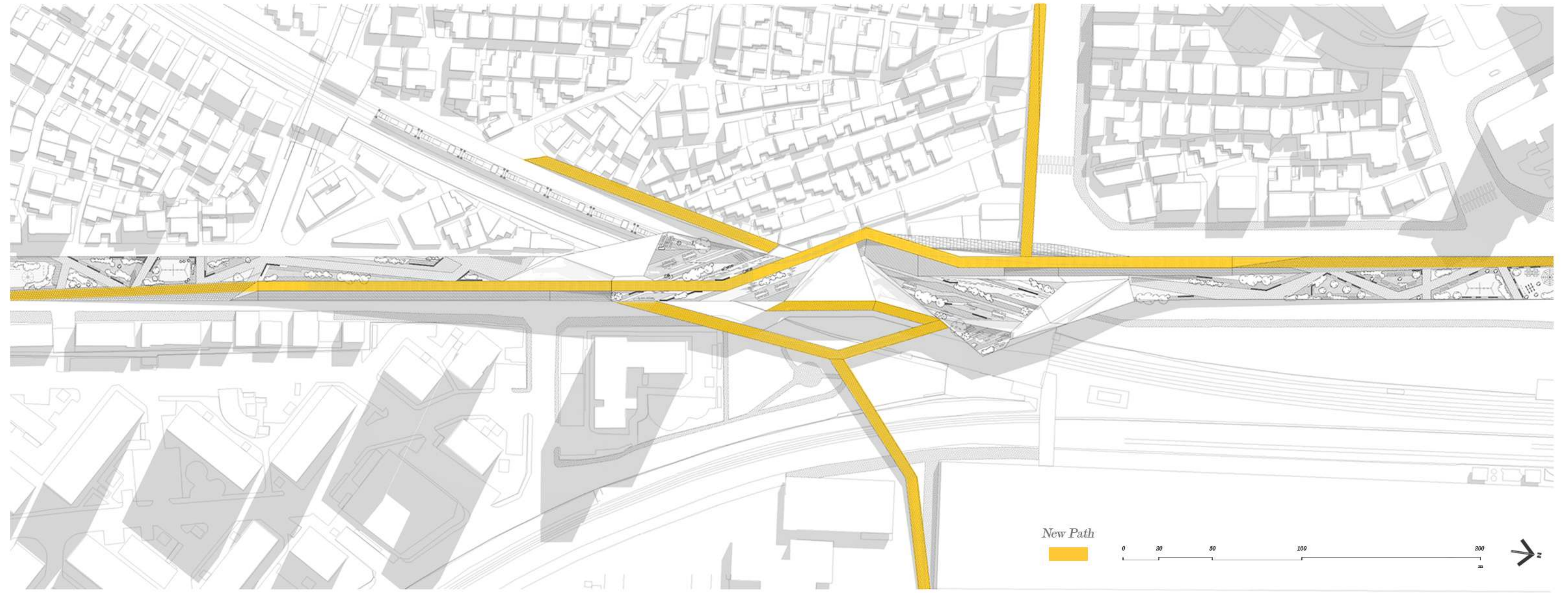

Conception of Circulation

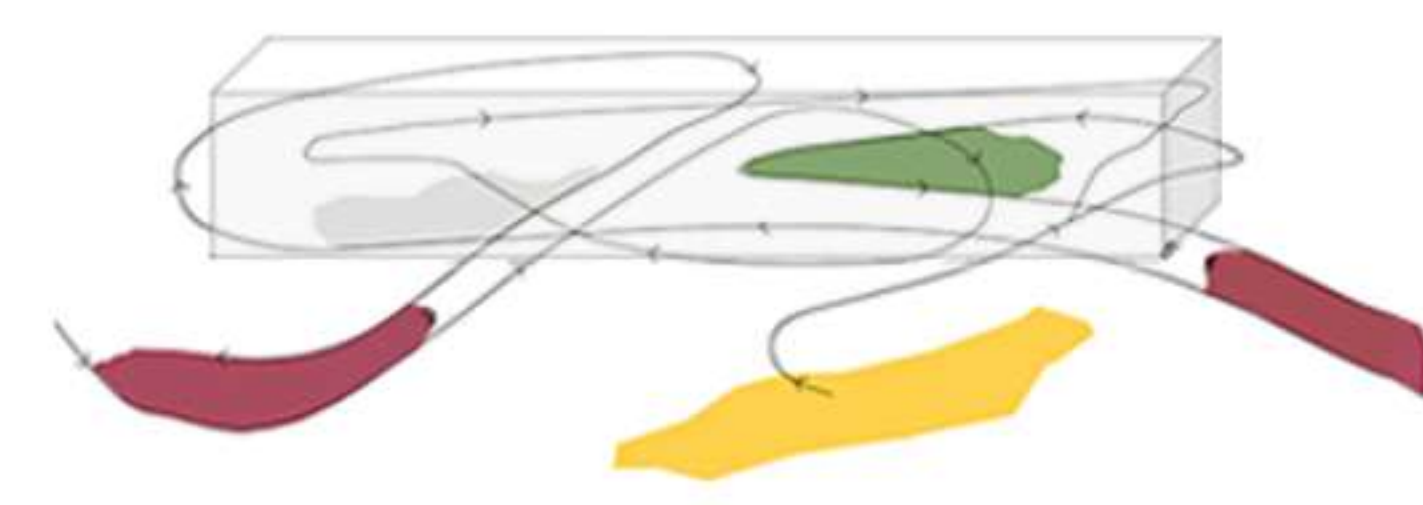

Circulation Concept Diagram

| **Interactive Facade** ; The concept of 'Interactive facade' has been established to convert pedestrians movements into design. It extends the walking path by inserting the pattern of the existing walkway into the station. The extended walkways connect each program organically to the interior and exterior, and the flow of walking is visualized by a three-dimensional walking environment.

The existing entrance to Shinyimun Station was maintained and a green area was created on the long historical path to turn it into a walking path. Through the pedestrian walkway, the connection between ddareungi, located in the lower part of the station, and the market was increased.



Visualize Movement

- Visualization of Walking Circulation

| a **Connected Neighborhood** ; The 'SHINYIMUN ; Connected Neighborhood' project is aimed at connecting and facilitating the flow of disconnected walking around Imun-dong. Since the focus was on promoting walking and increasing the amount of walking, the flow of walking is revealed on the exterior of the building and the plan itself is to become a building, and drawings and models are expressed. By adjusting the slope of the walkway, the slow and medium-speed walking environment is adjusted and the core is properly placed for functional movement and evacuation.

Visualized Circulation

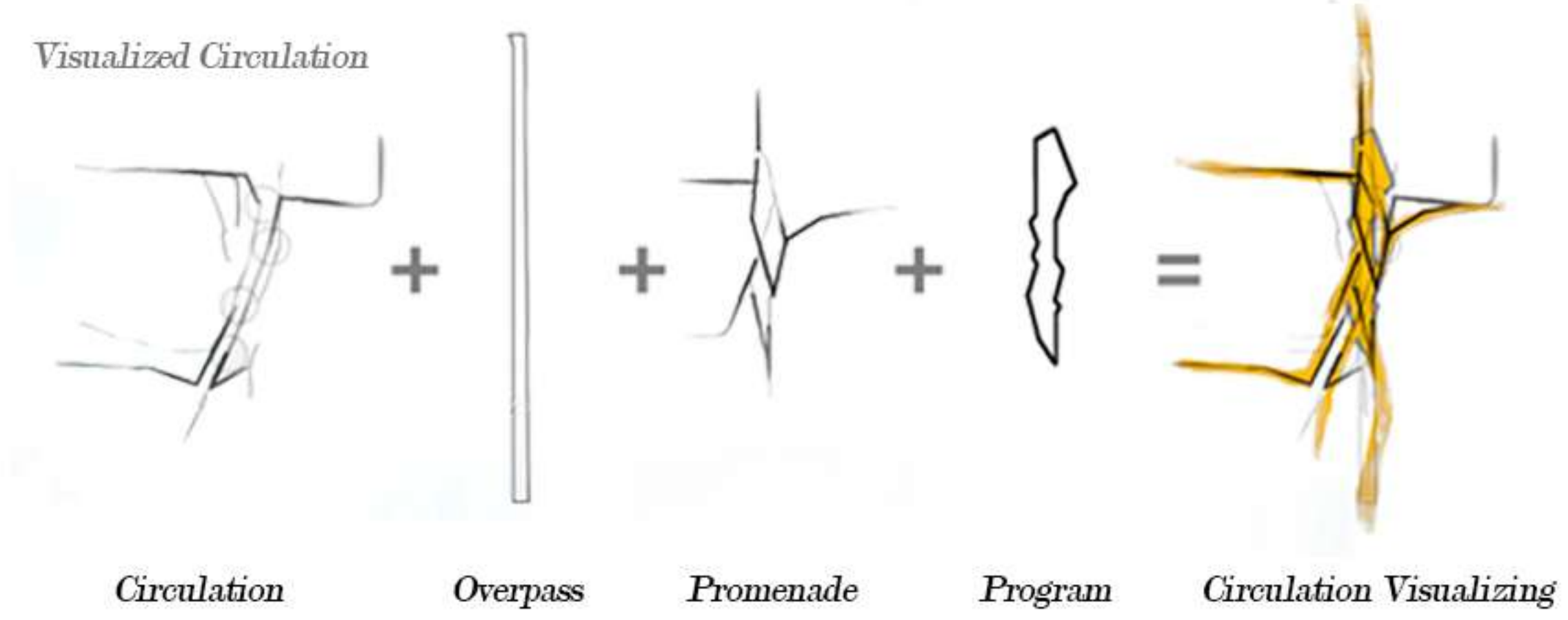

Perspective View



Drawing

WEST ELEVATION

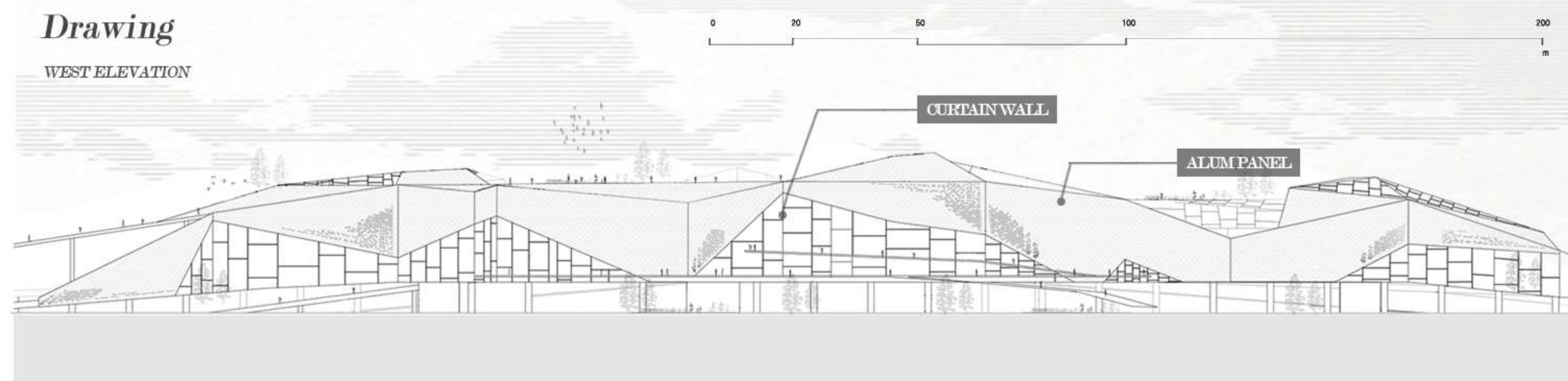

EAST ELEVATION

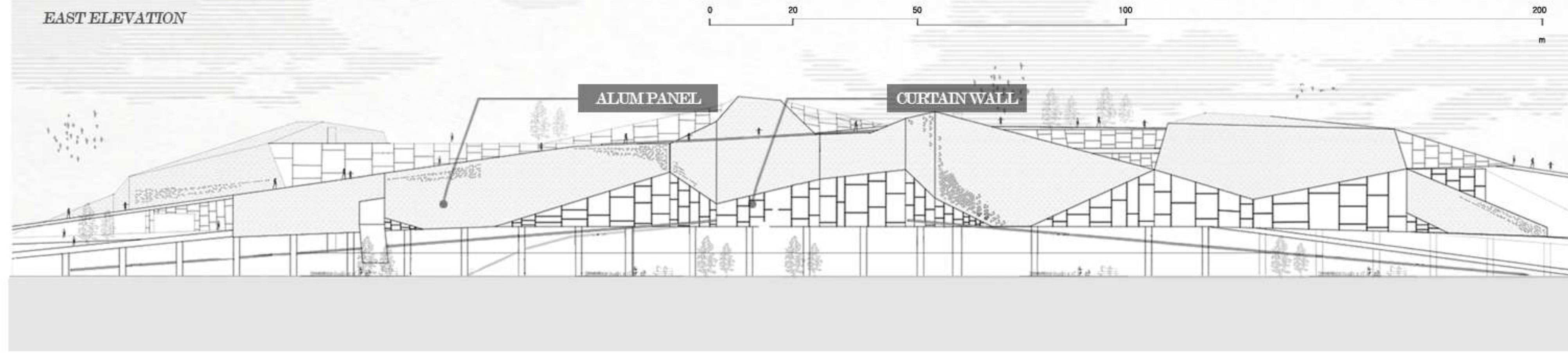

SECTION

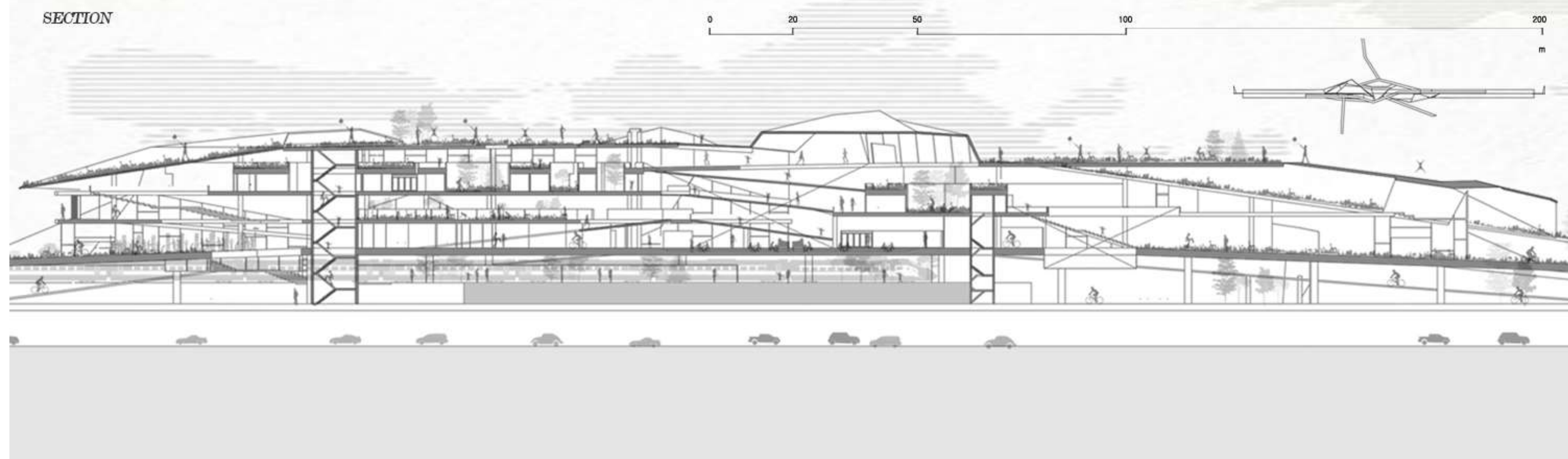

SHINYIMUN ; Connected Neighborhood



2019 KRA Awards

2035 Modular Cloud Platform

- Relationship Between COVID-19 & Modular Architecture



Individual Project



Social distancing has become routine to prevent proliferation concerns and the trigger of a new epidemic. Physical quarantine through social distance and architecture has succeeded in reducing population density. But the volume of the city had to increase to realize this. Most companies that have been working from home since Covid-19 will return to their offices due to the increased density of urban space. Now, the city operates by creating and assembling as much space as necessary, and dismantling spaces that reduce demand.

2020 SMA Competition

Synopsis

- Volumetric City for Social Distance

| **Undeveloped FAR** ; Seoul, which has an ultra-dense environment, is trying to increase the volume of the city to reduce population density. To accommodate existing programs while reducing population density, the physical volume of the city must be increased.

However, Seoul, which no longer has land for new buildings, will propose a bill to develop and promote the undeveloped FAR of skyscrapers. Seoul will increase the volume of the city vertically. Cities are becoming increasingly high-rise and low-density. Modular architecture is actively utilized to actively respond to the environment of these cities.

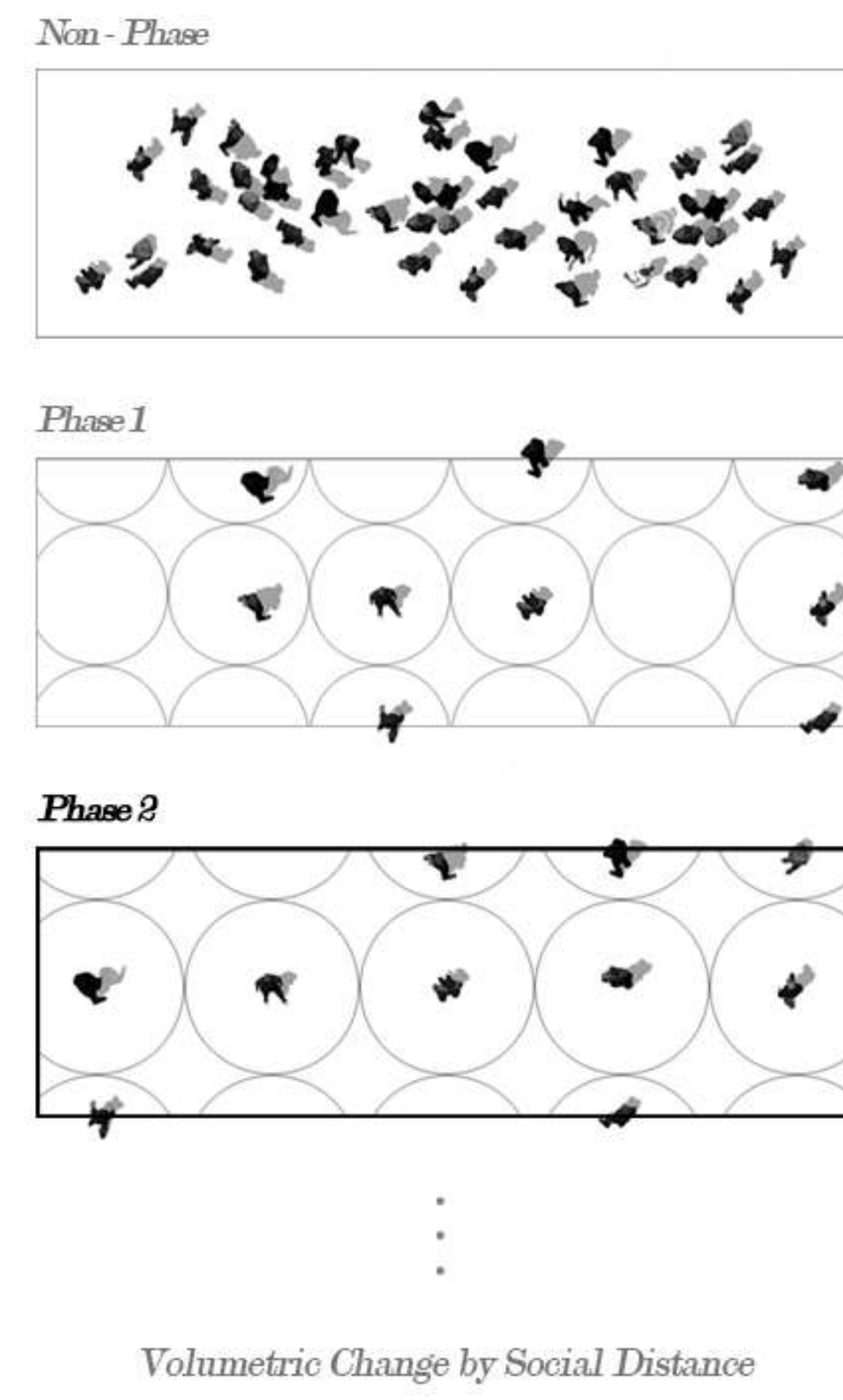

Programing for Aerial City

- Undeveloped FAR of GANGANAM

Drone's Eye View

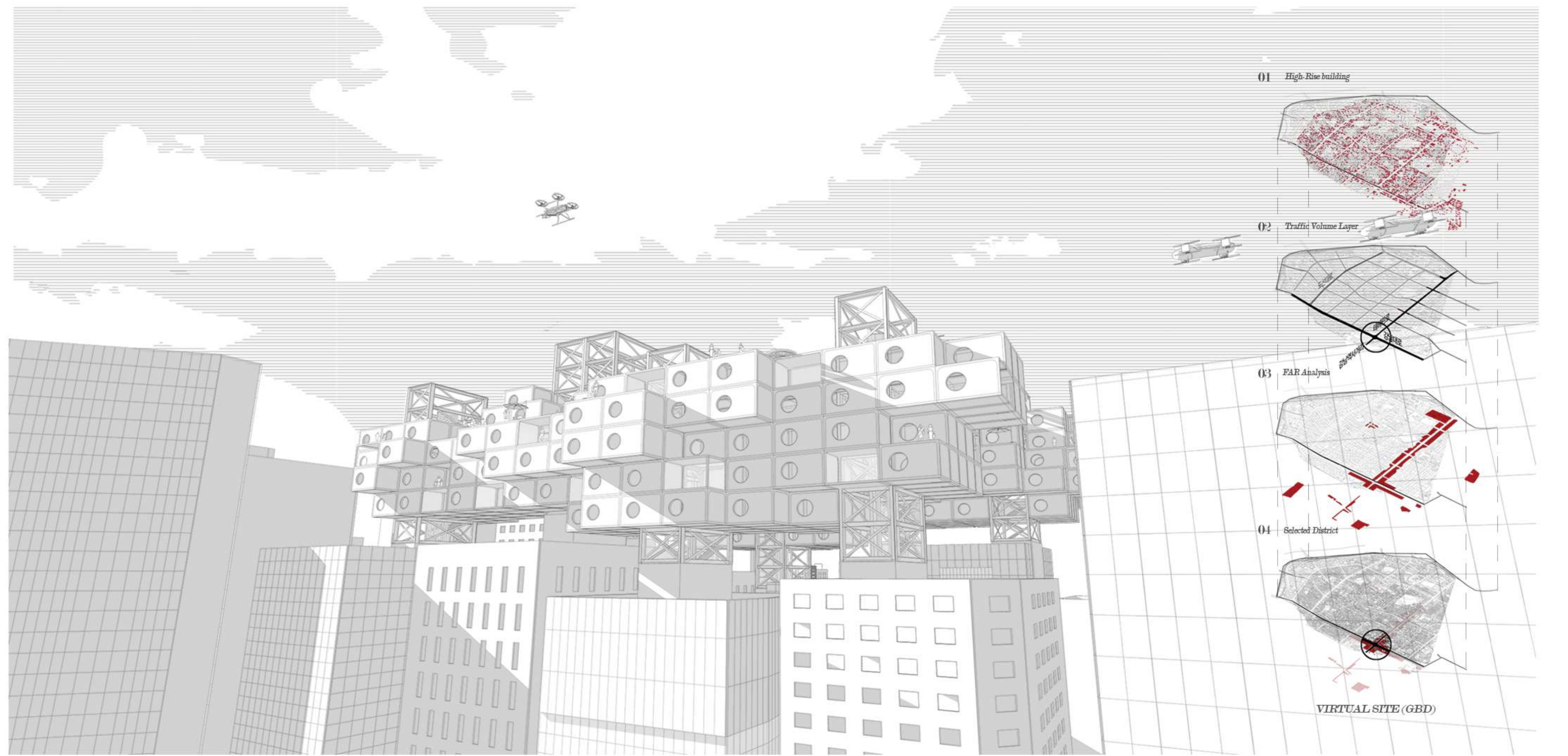

| **Programing** ; Employees who used existing work spaces by modular architecture will be guaranteed a wider and more pleasant work space as urban space density increases. The high-rise of urban space weakens the interface between people and the ground. Therefore, users in skyscrapers have less access to parks that can only be experienced on the ground. To solve this problem, a public park was proposed as a program to secure the green area of the skyscraper. In this context, there is a problem that the interface with two-dimensional transportation in ground space is weakened. This problem will activate three-dimensional mode of transportation. Therefore, I proposed a three-dimensional transportation platform.

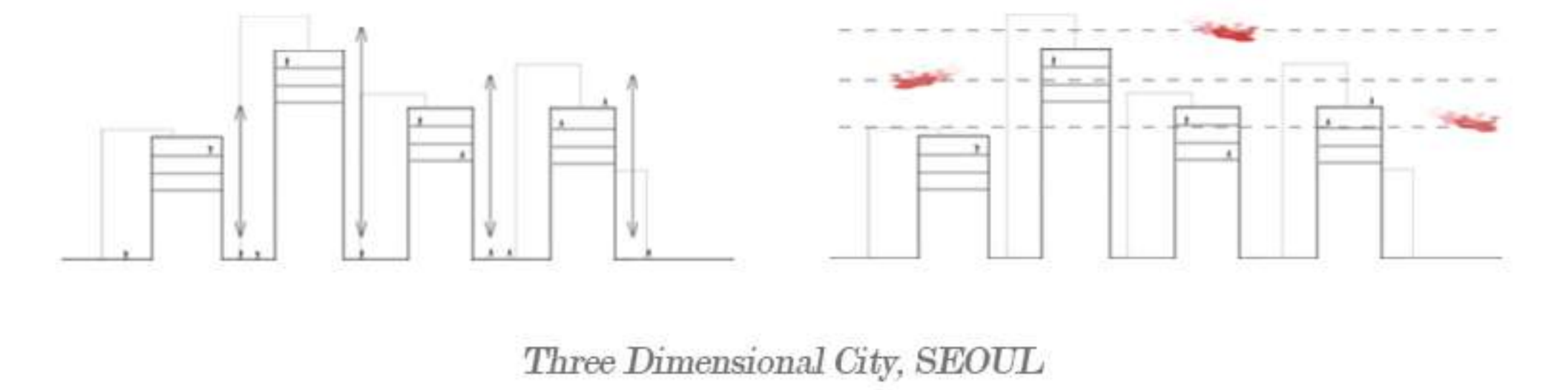

Mobility Scale & Expandability Module

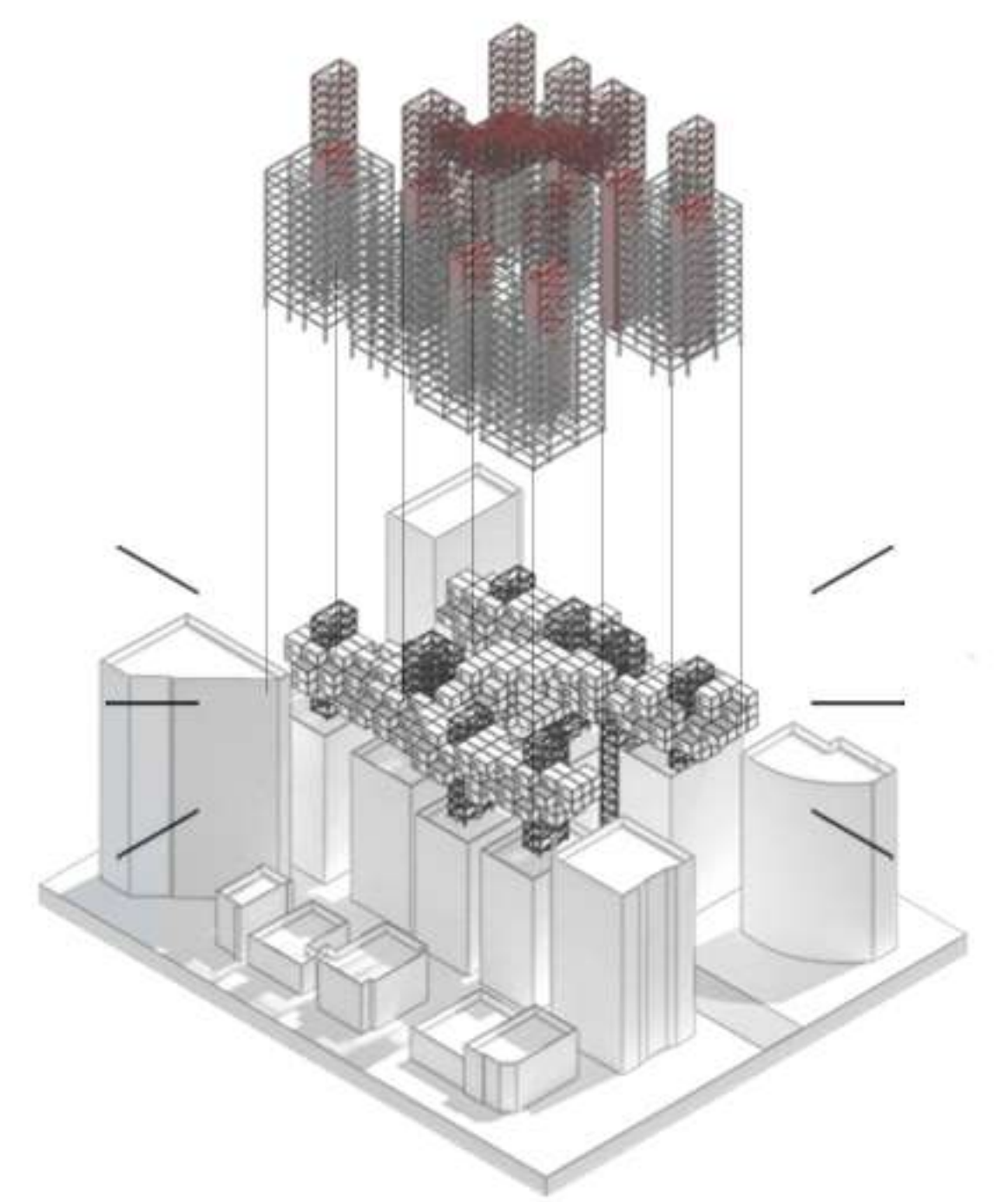
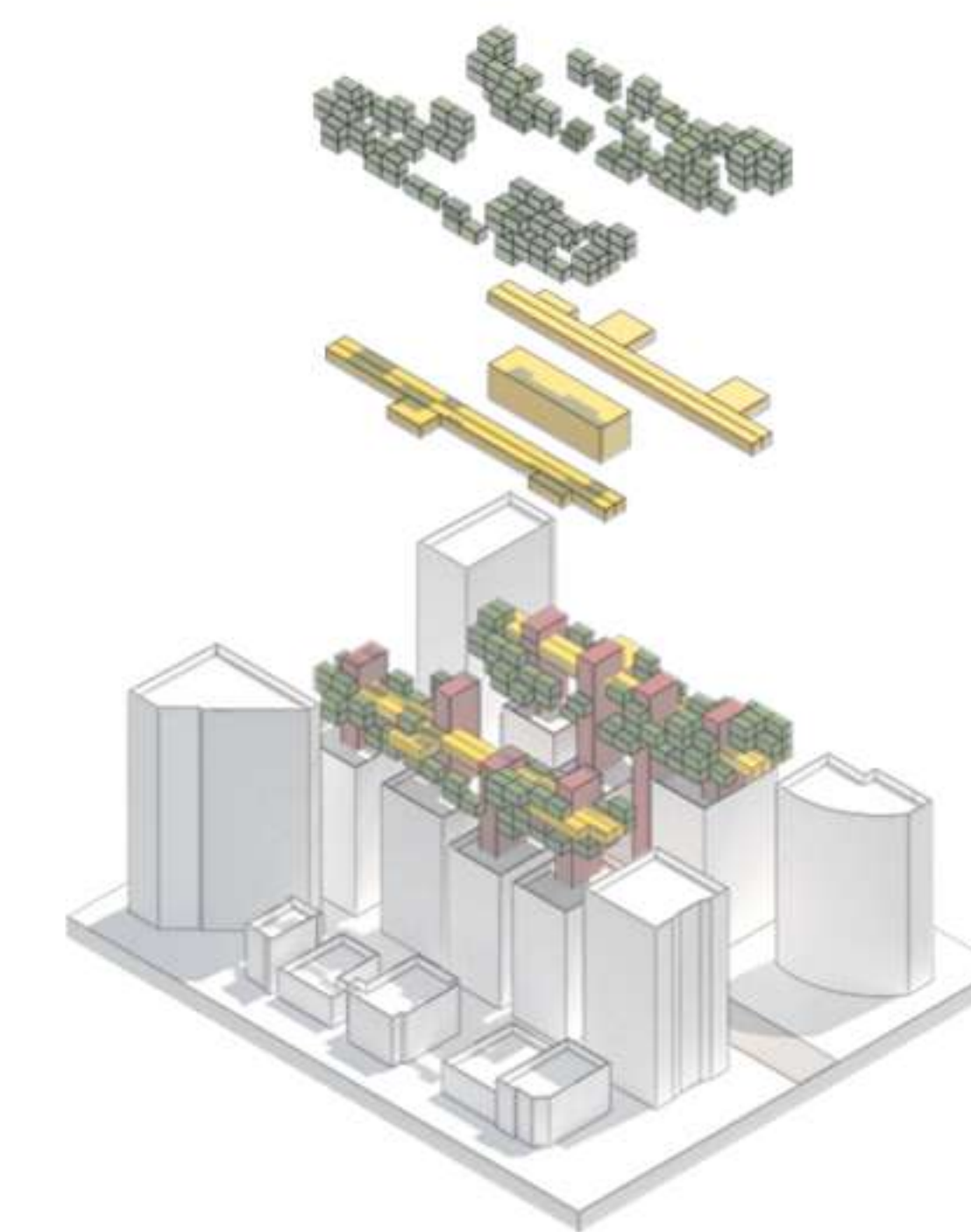
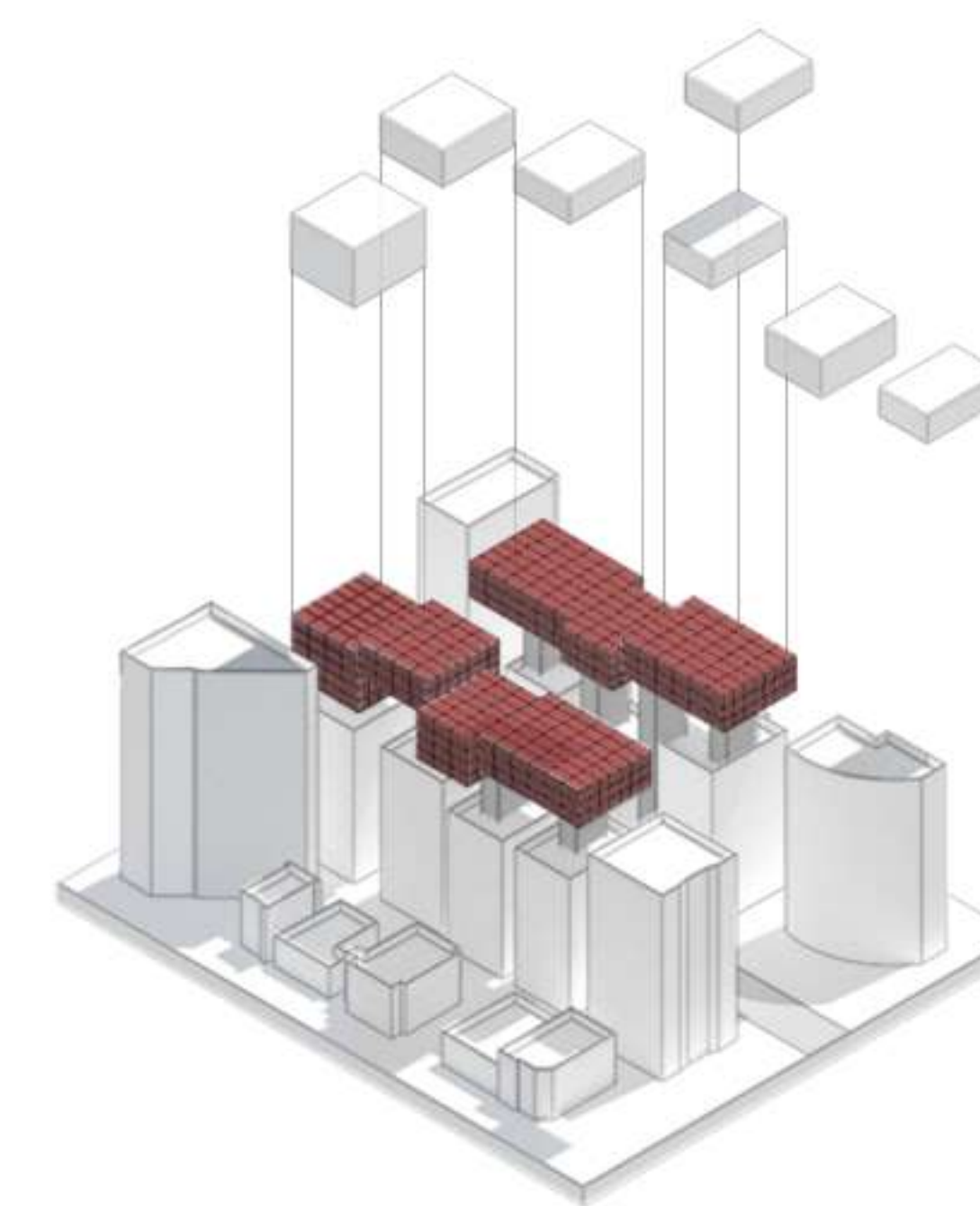
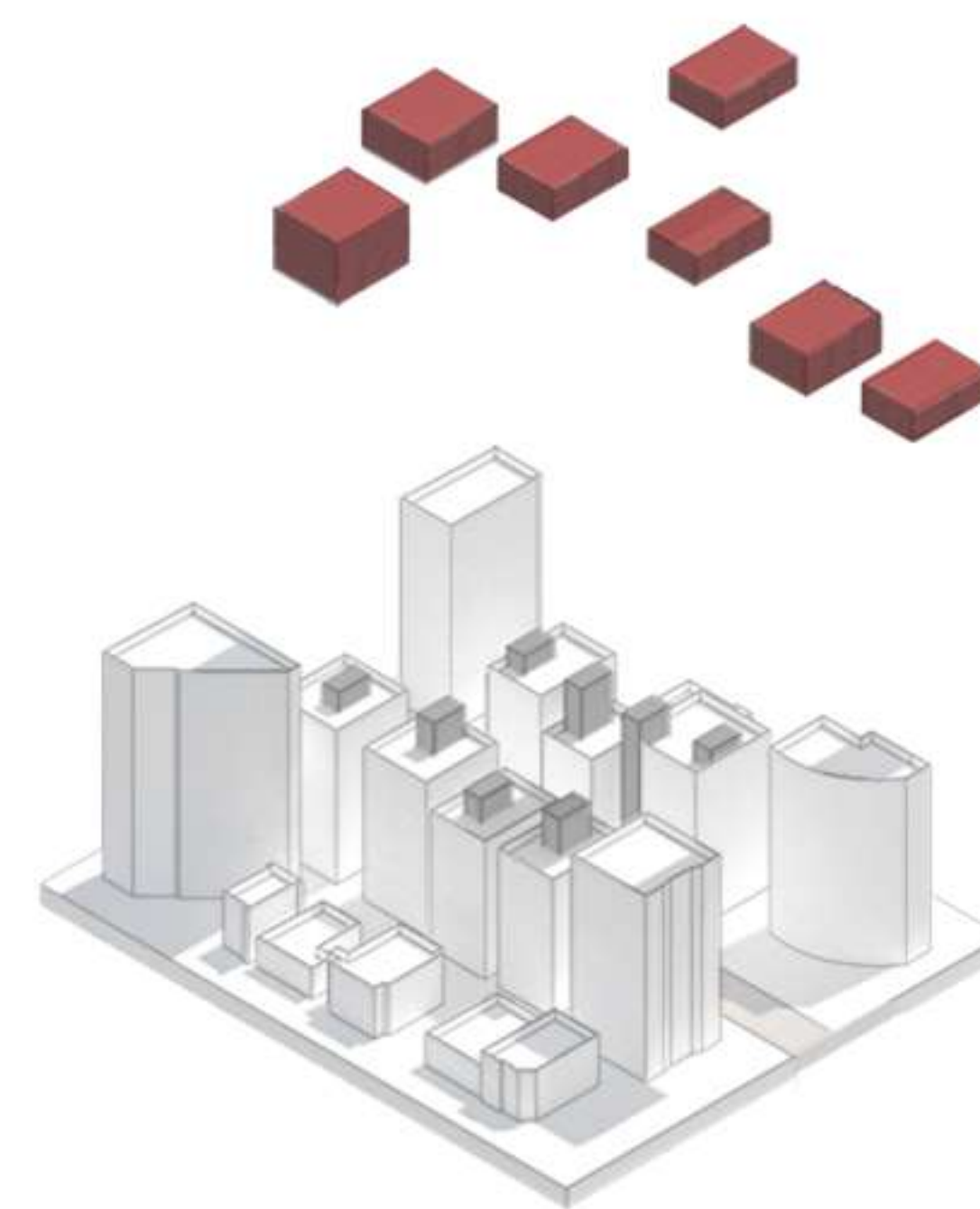
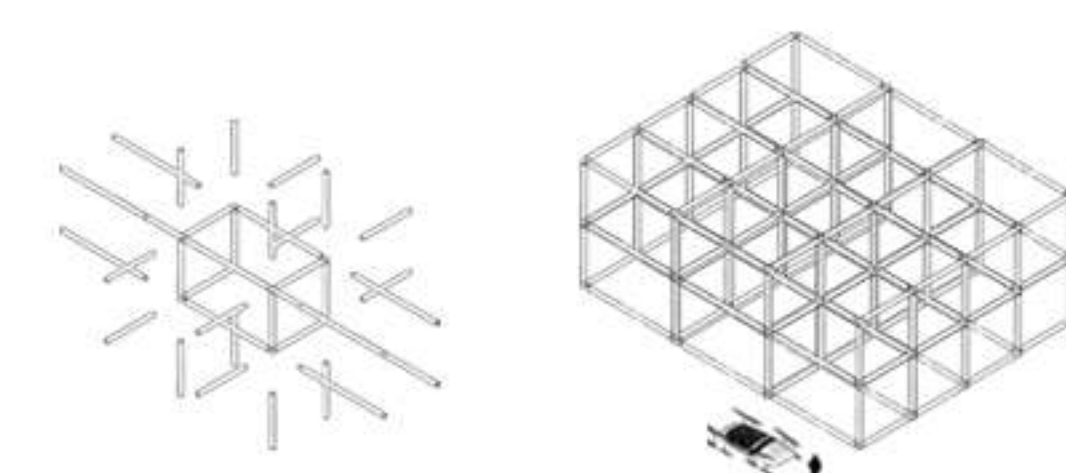

Expandable City

- Responding to changes in space demand

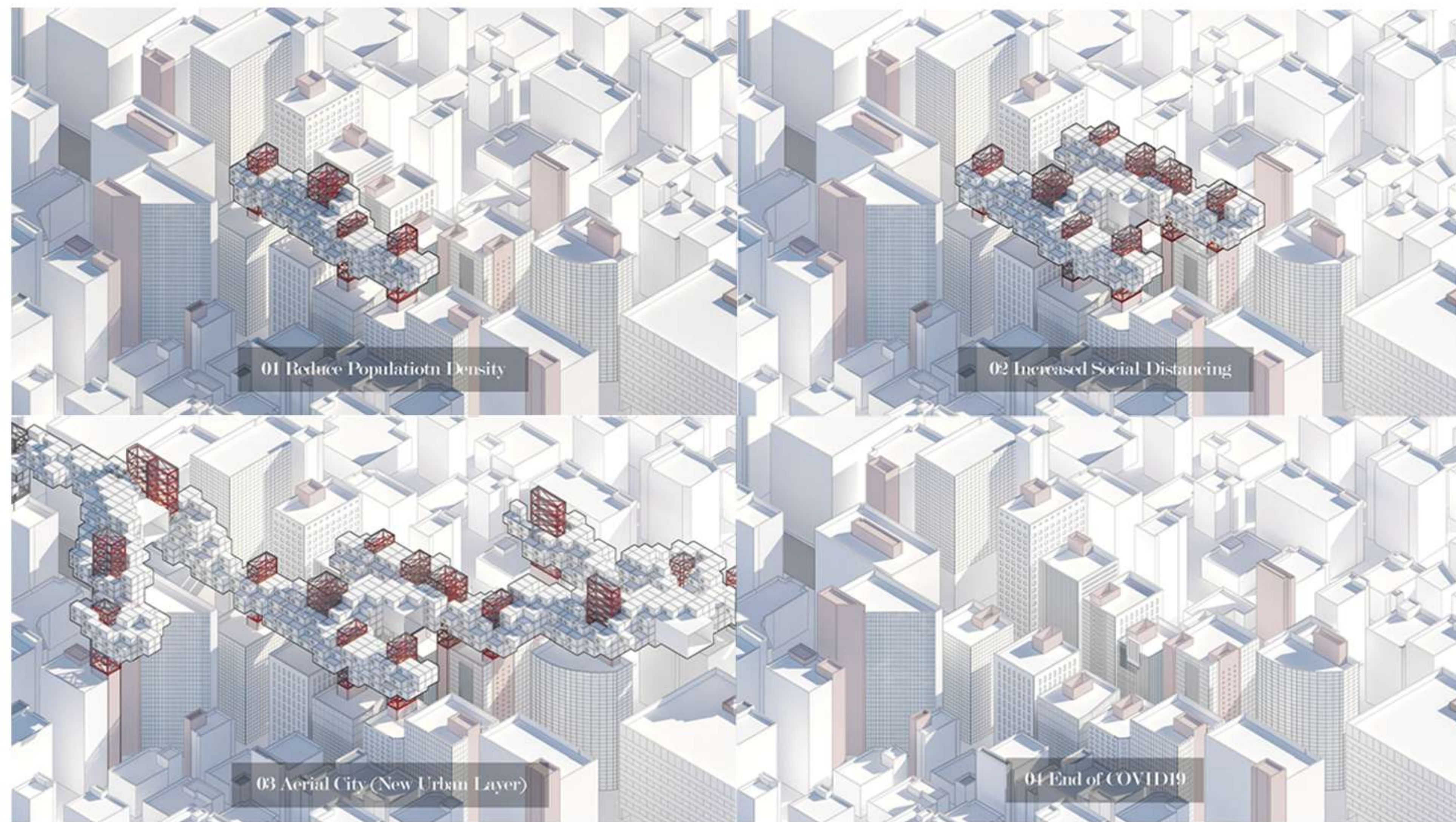

| The Modular City ; By virtue of the advantages of modular architecture, the city is assembled and dismantled, controlling the volume. To optimize the members that thicken when multiple modules are stacked, the design is shown below. It also braces to make the load flow between modules flexible and draws module-to-module, module-to-truss joint details. This design logic will create an aviation city in Seoul and return to its original state after Covid-19 is over.

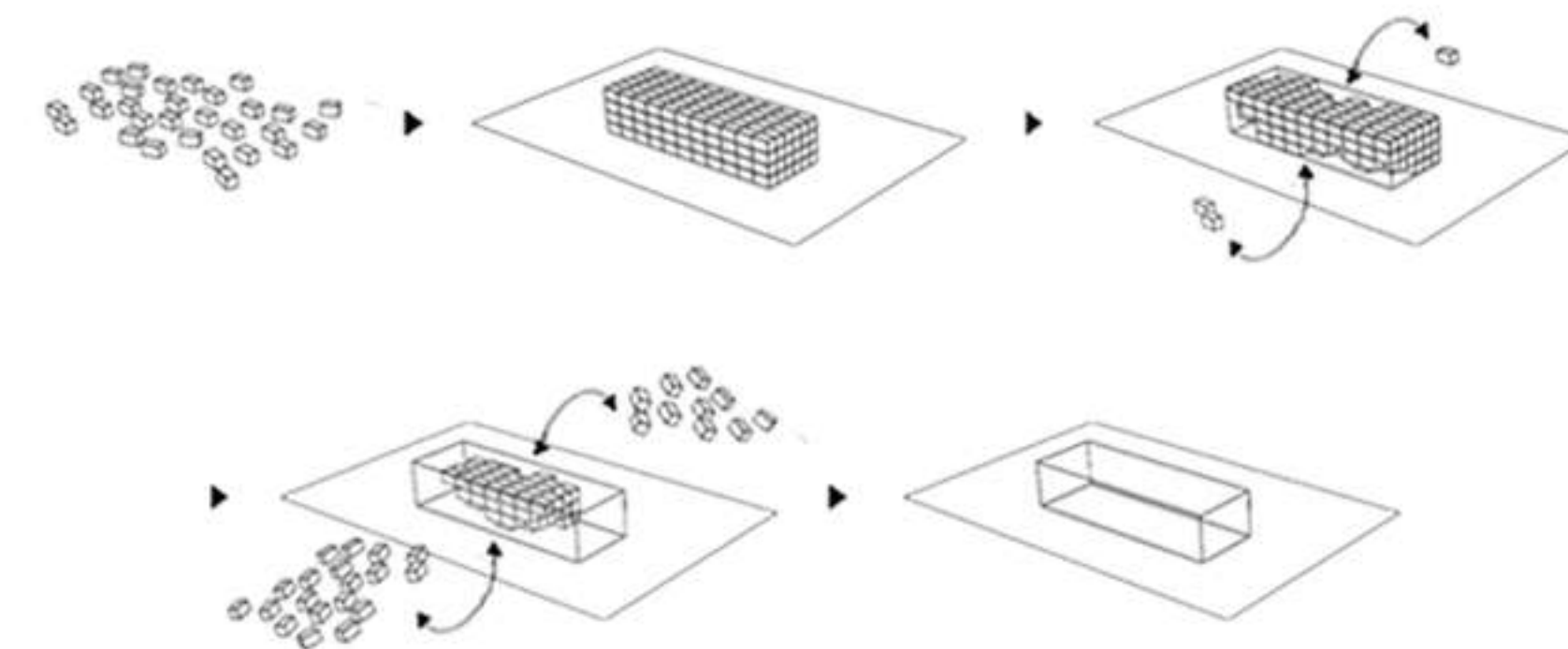

New Normal City for COVID-19: The Aerial City

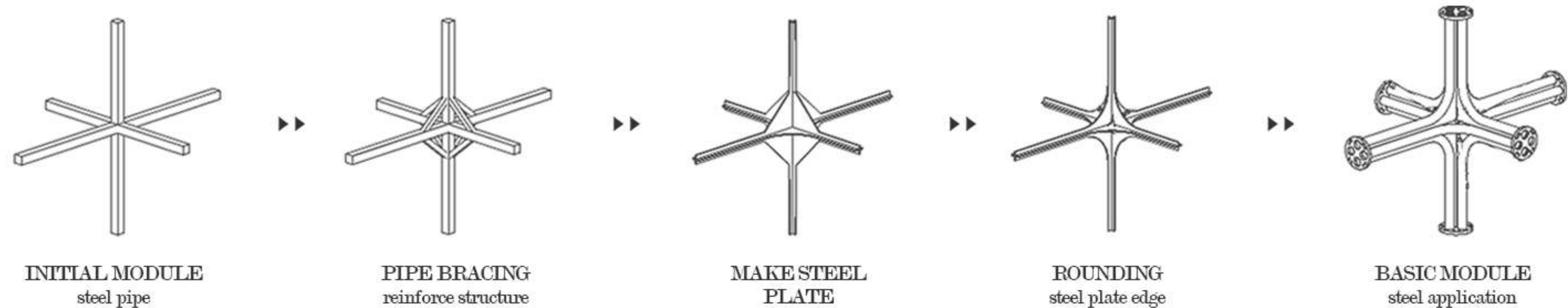

INITIAL MODULE steel pipe PIPE BRACING reinforce structure MAKE STEEL PLATE ROUNDING steel plate edge BASIC MODULE steel application

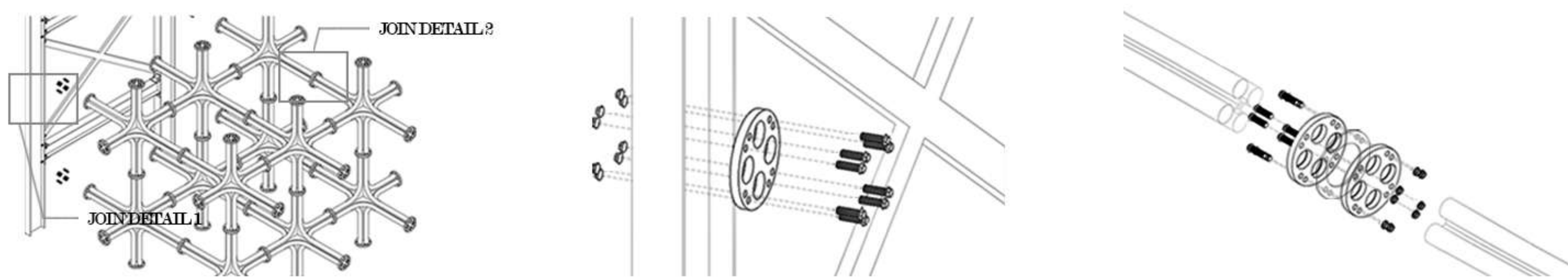

DETAILED STRUCTURE MODELING JOIN TRUSS STRUCTURE & MODULE JOIN MODULE & MODULE

Structural Conception

- Modular Structure Analysis

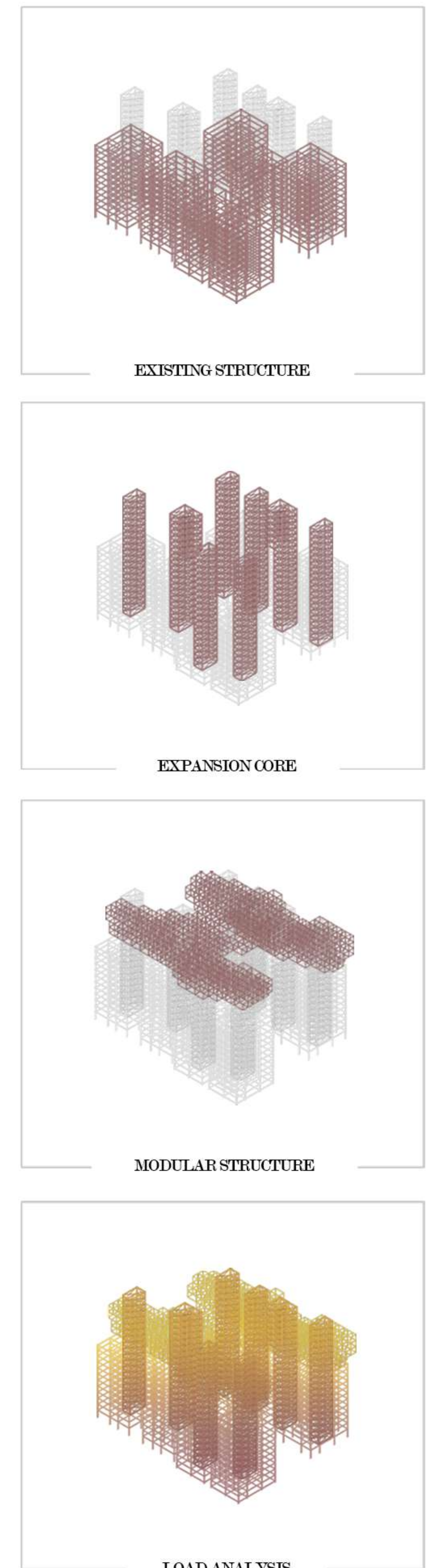

Parasitic Structure

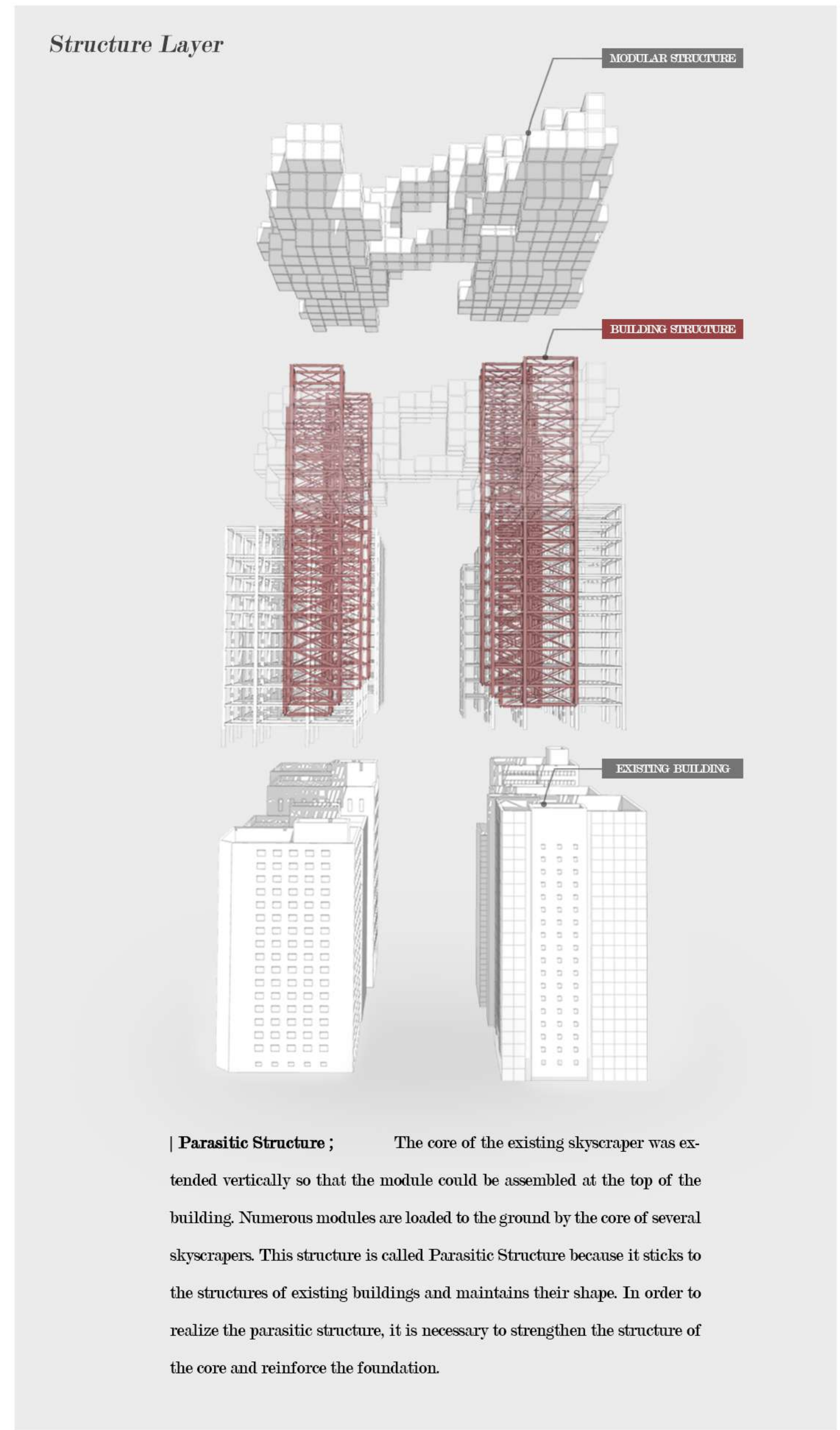

| Parasitic Structure ; The core of the existing skyscraper was extended vertically so that the module could be assembled at the top of the building. Numerous modules are loaded to the ground by the core of several skyscrapers. This structure is called Parasitic Structure because it sticks to the structures of existing buildings and maintains their shape. In order to realize the parasitic structure, it is necessary to strengthen the structure of the core and reinforce the foundation.

Drawing Conception

- Free Plan & Section Drawing

Idea ; A cross-shaped structural column is shown in the plane by the structural members of the braced module. Because it is structurally stable, it is possible to remove some columns and plan planes and cross sections as needed. At the entrance level of mobility, a drive-through plane is constructed to allow access to programs without getting off the vehicle. Also core is extended vertically so that each floor can be moved vertically on vehicle. As above, we established the logic for drawing and proceeded with drawing work.

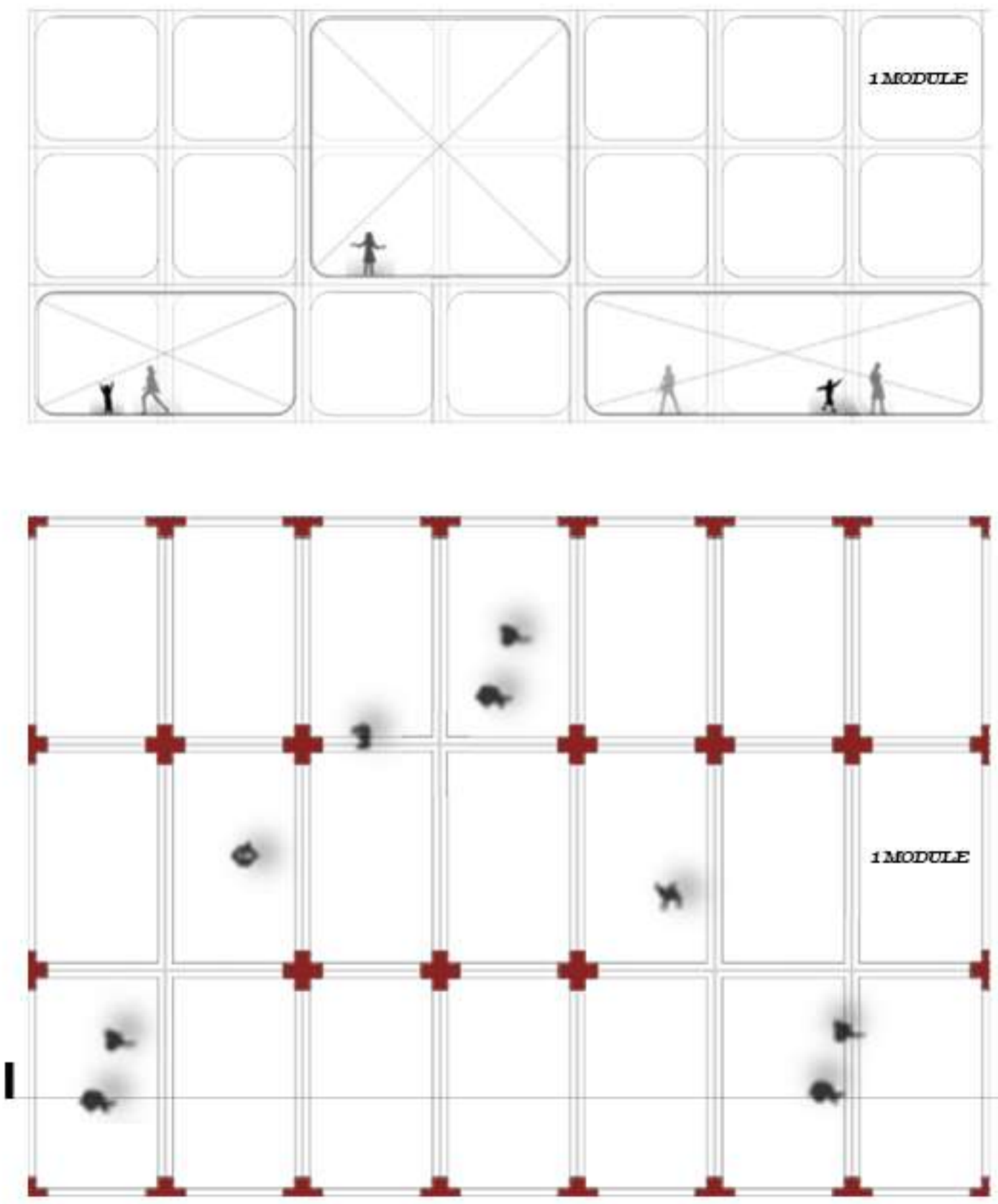

Drawing Conception Diagram (Plan & Section)

Mobility Scale

- Programing for UAM

DT Platform ; The process of building and programming the size of the module to the scale of the UAM used upper and lower openings to increase accessibility between the ride and the commercial space. As seen in the cross section, the core allows the vehicle to move vertically through all floors, and the shop is easily accessible through driving tracks and upper and lower openings. Separates between vehicle movement and human movement. And traffic lights and crosswalks are introduced where the two people overlap to facilitate traffic.

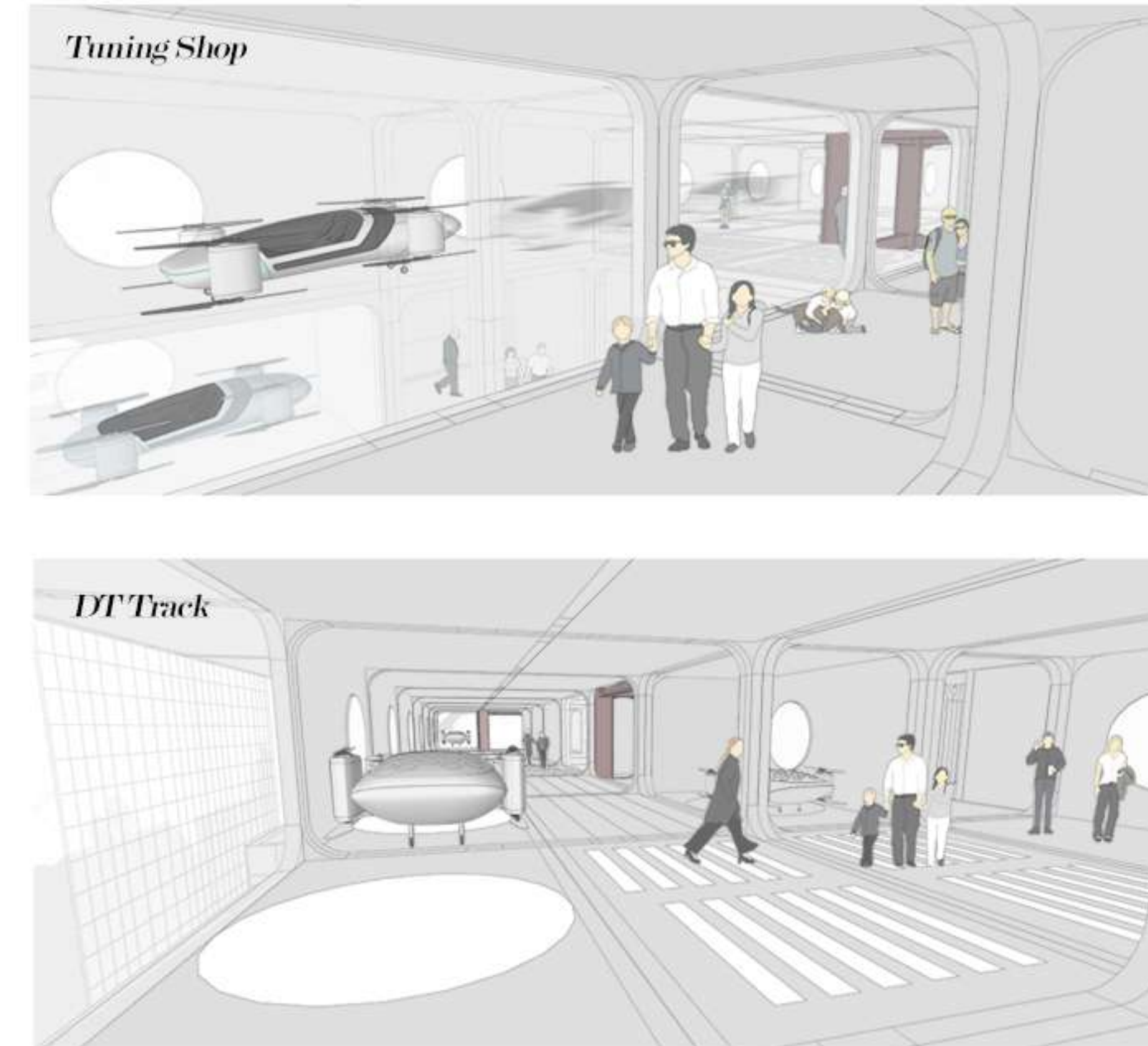

- Program Zoning

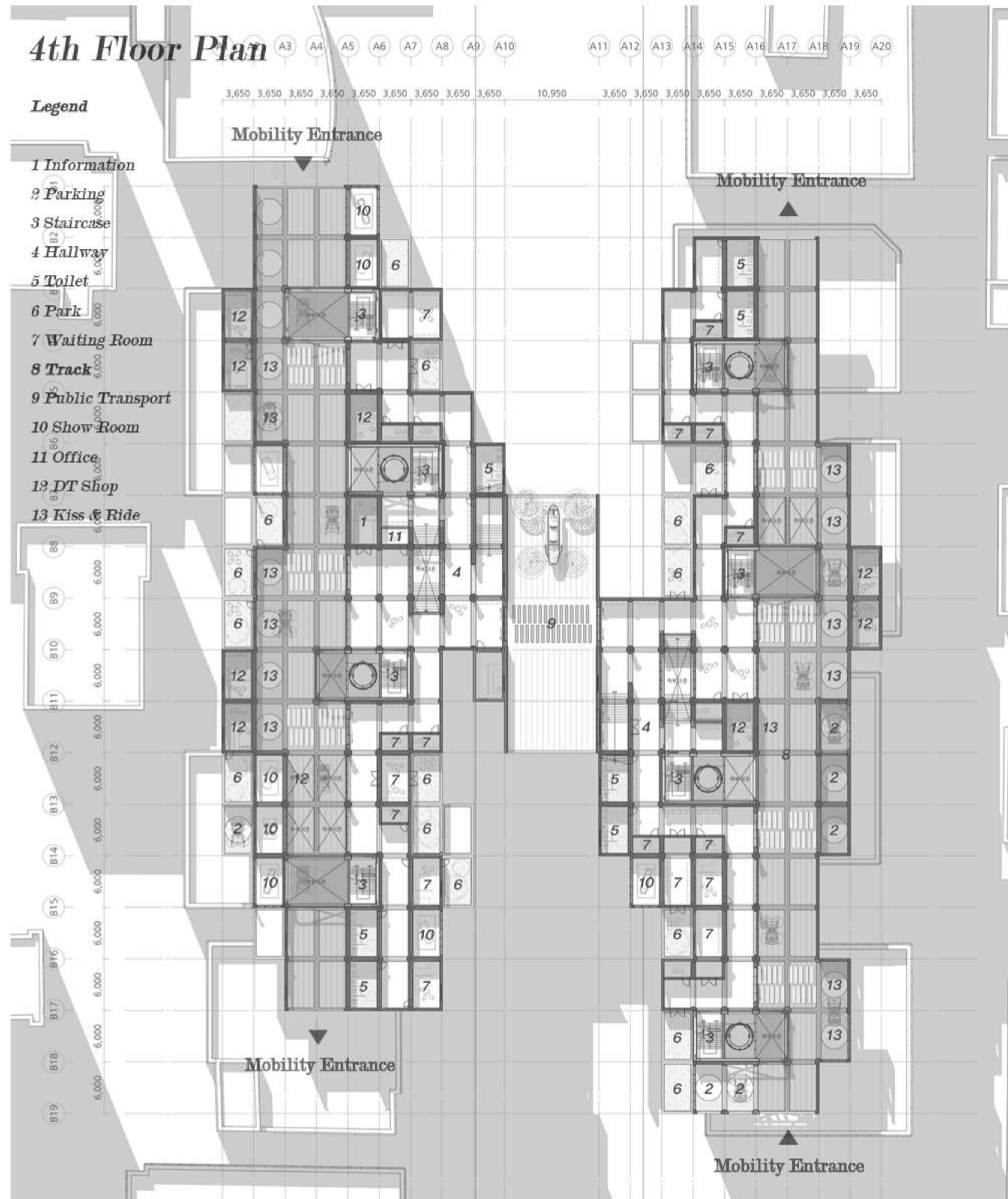
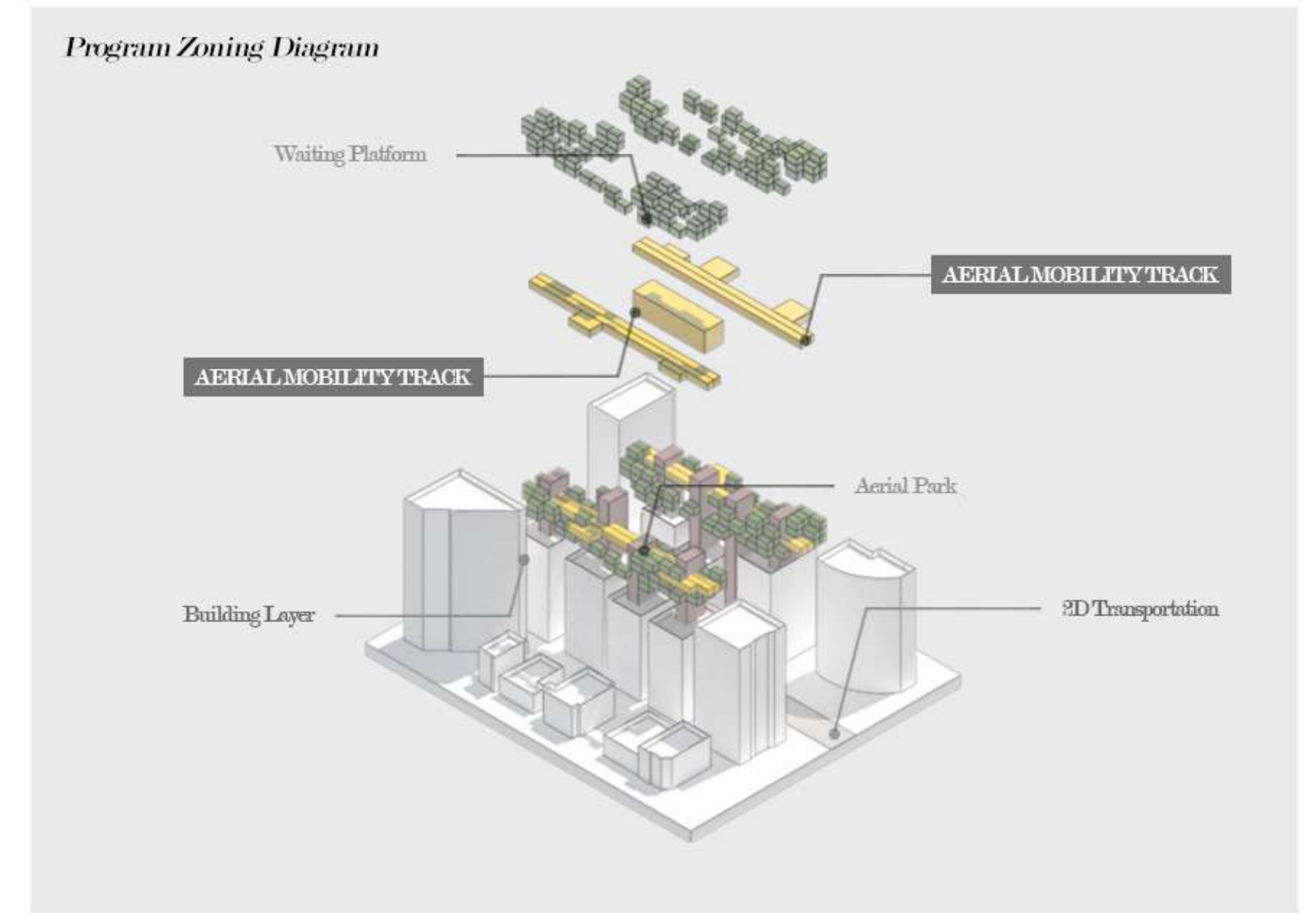

Conceptual Section

Legend

- 1 Waiting Room
- 2 Park
- 3 Cafe
- 4 Terrace
- 5 Hallway
- 6 Toilet
- 7 Office
- 8 Track
- 9 Tuning Shop

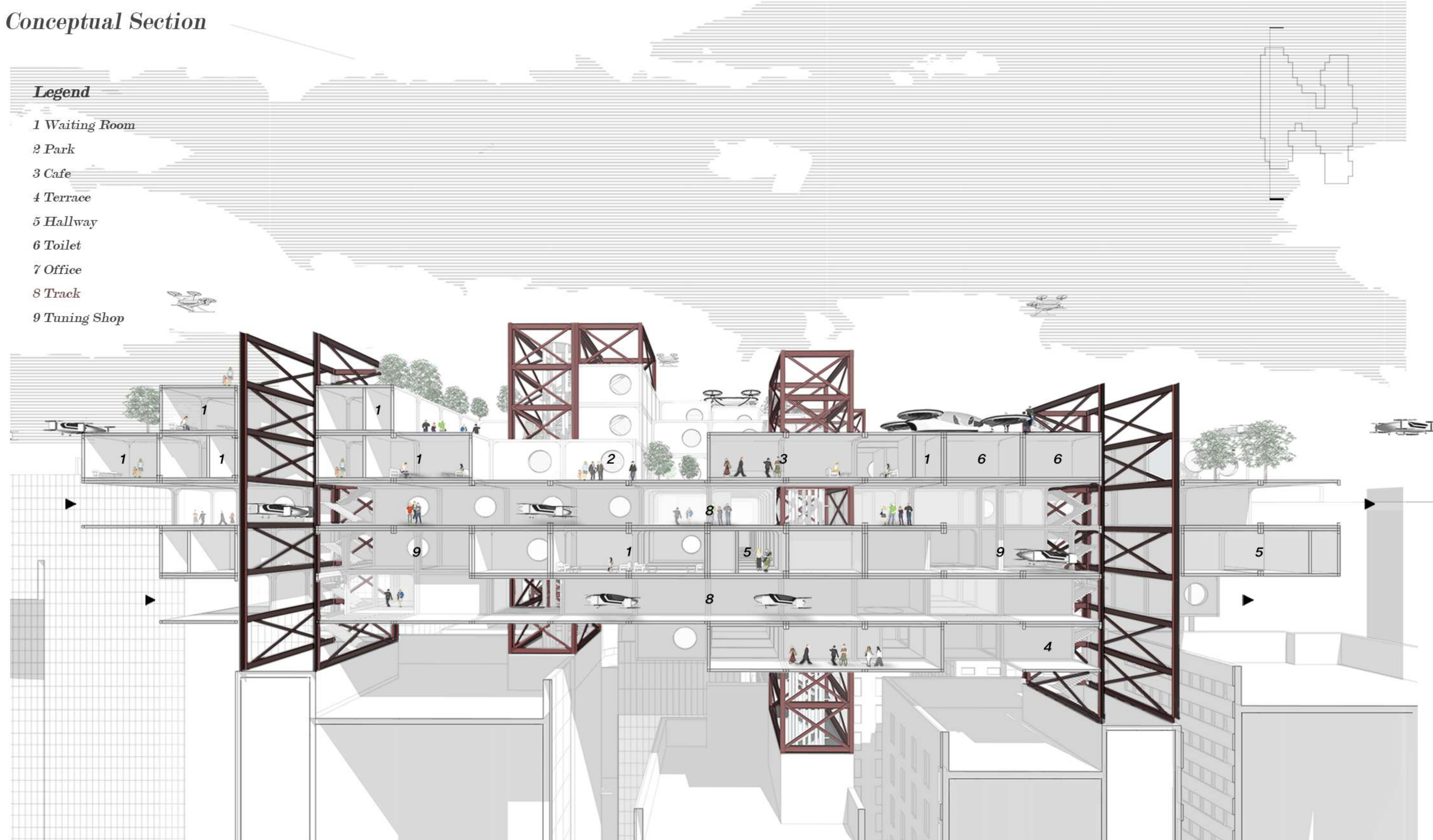

Grown Scape

- Grown Building; Remodeling Project

GROWING TREE

Individual Project

GROWING BUILDING

GROWING TREE

Chungju Cultural Center was established to promote the rich cultural life of Chungju residents and to inherit and develop traditional culture. The Chungju Cultural Center is now out of existing function as it grows older. After a long time since 1965, trees in the Tangeumdae forest have grown, but the cultural center has not.

People who know what the old cultural center looked like after the extension say the building has grown.

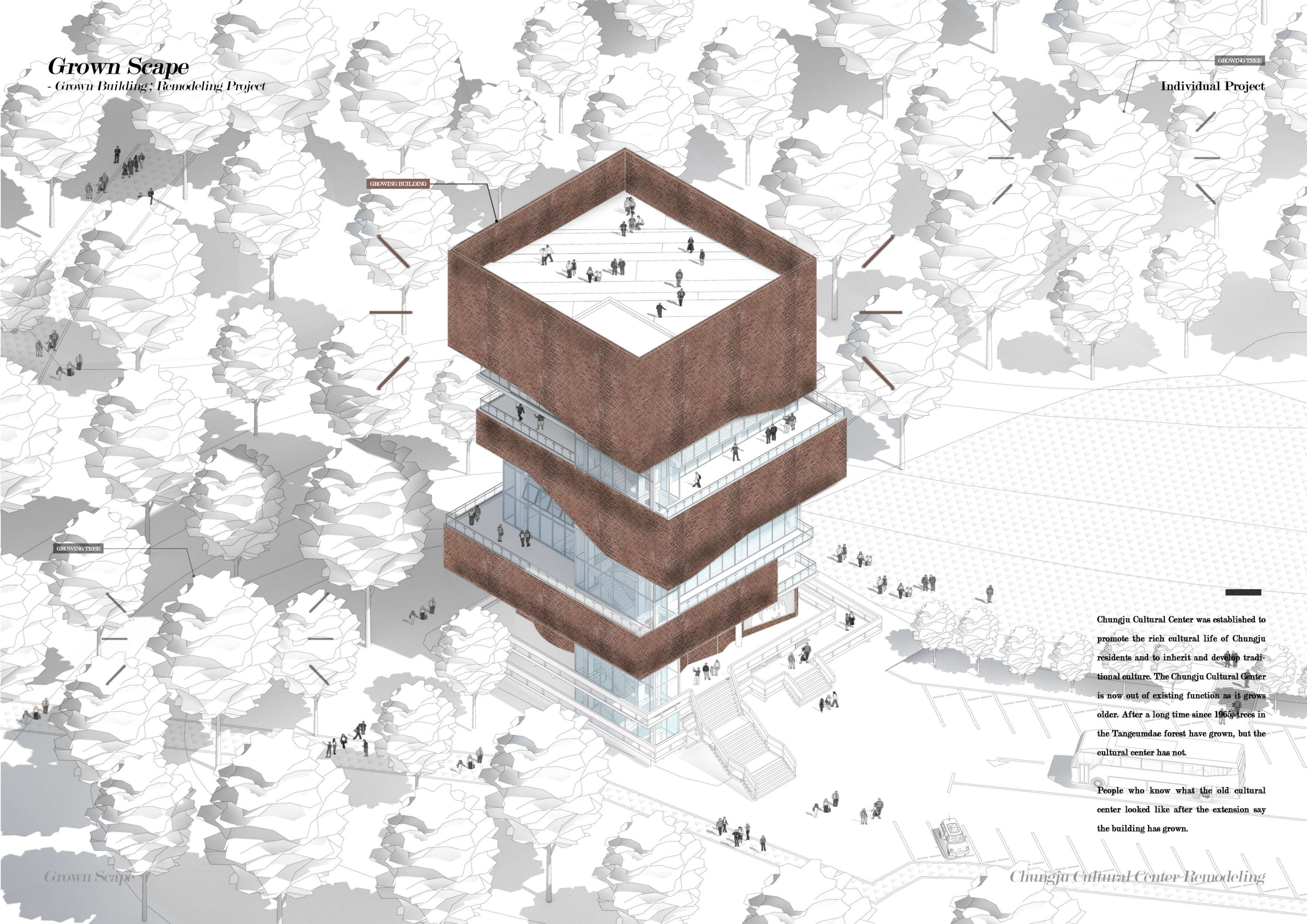

Synopsis

- Grown Trees, Ungrown Building

| Ungrown Building ; Surrounded by dense forests, the cultural center sits like a tree. In the past, the cultural center was able to view the Namhangang River, which flows to the north of Tangeumdae, from the rooftop. After a long time, the surrounding trees have grown taller and today they have lost their function to view. I decided to extend vertically to restore the function of the view and not harm the trees around us. First, I planned to restore the lost view and proceeded with the analysis of the scenery.

Time Line

Grown Trees, Ungrown Building

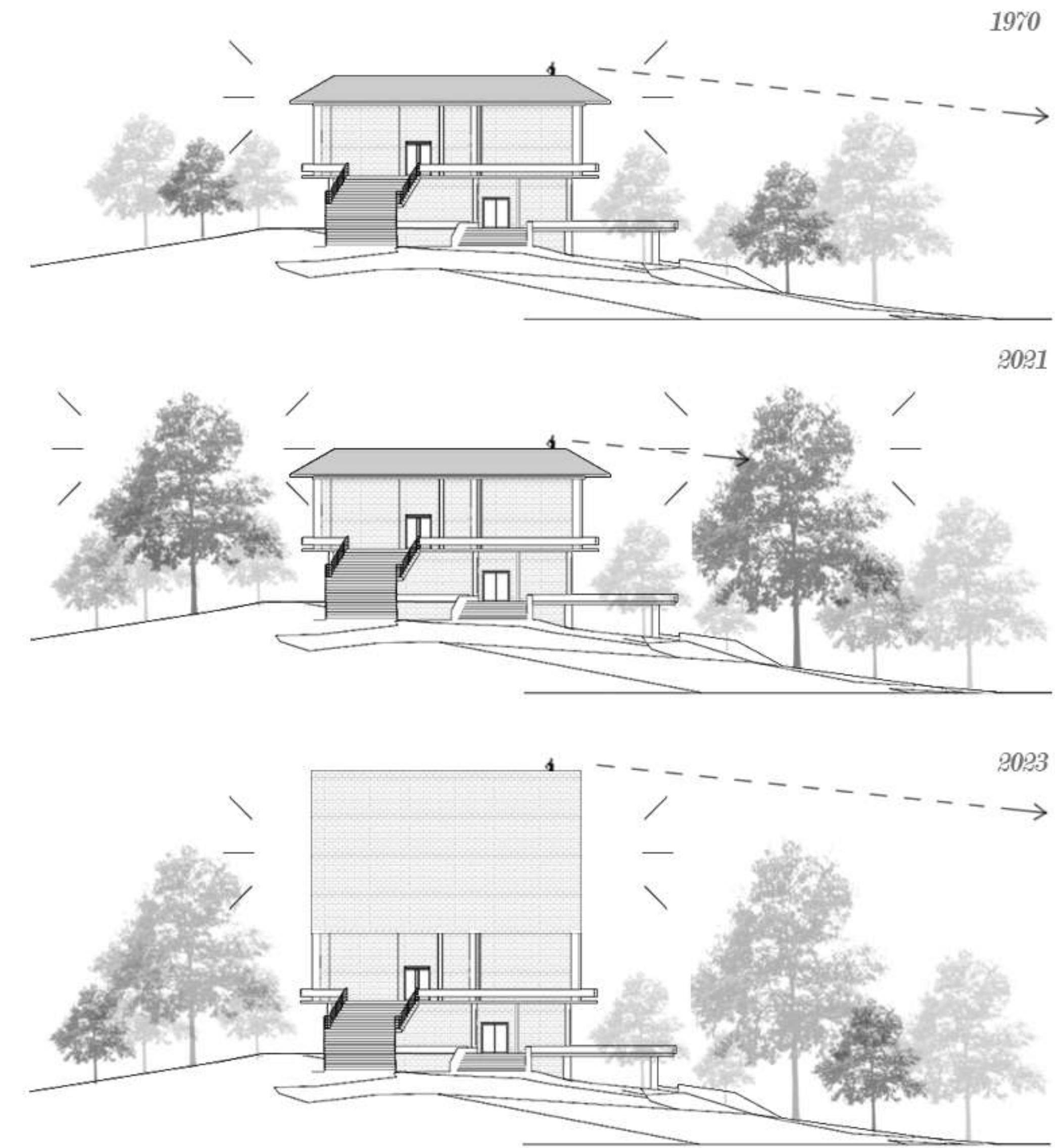

Existing Condition

Present Site Plan

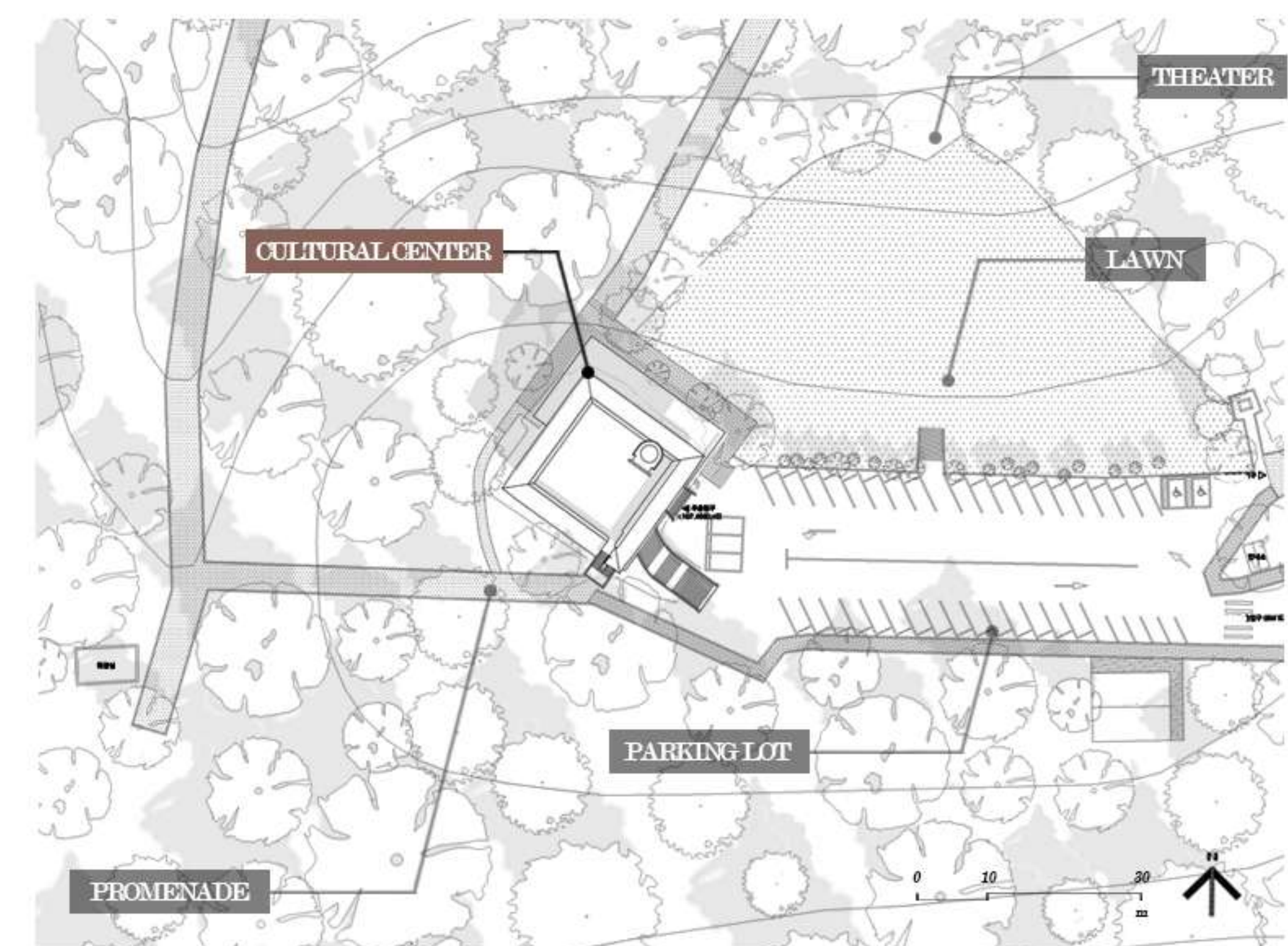

Grown Scape

Suggestion

- Recover Landscape View

Design Process

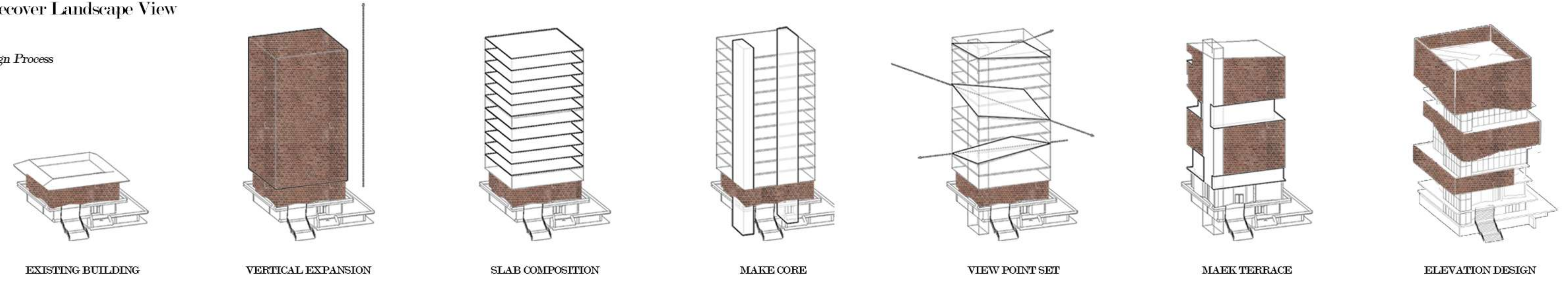

Main Program

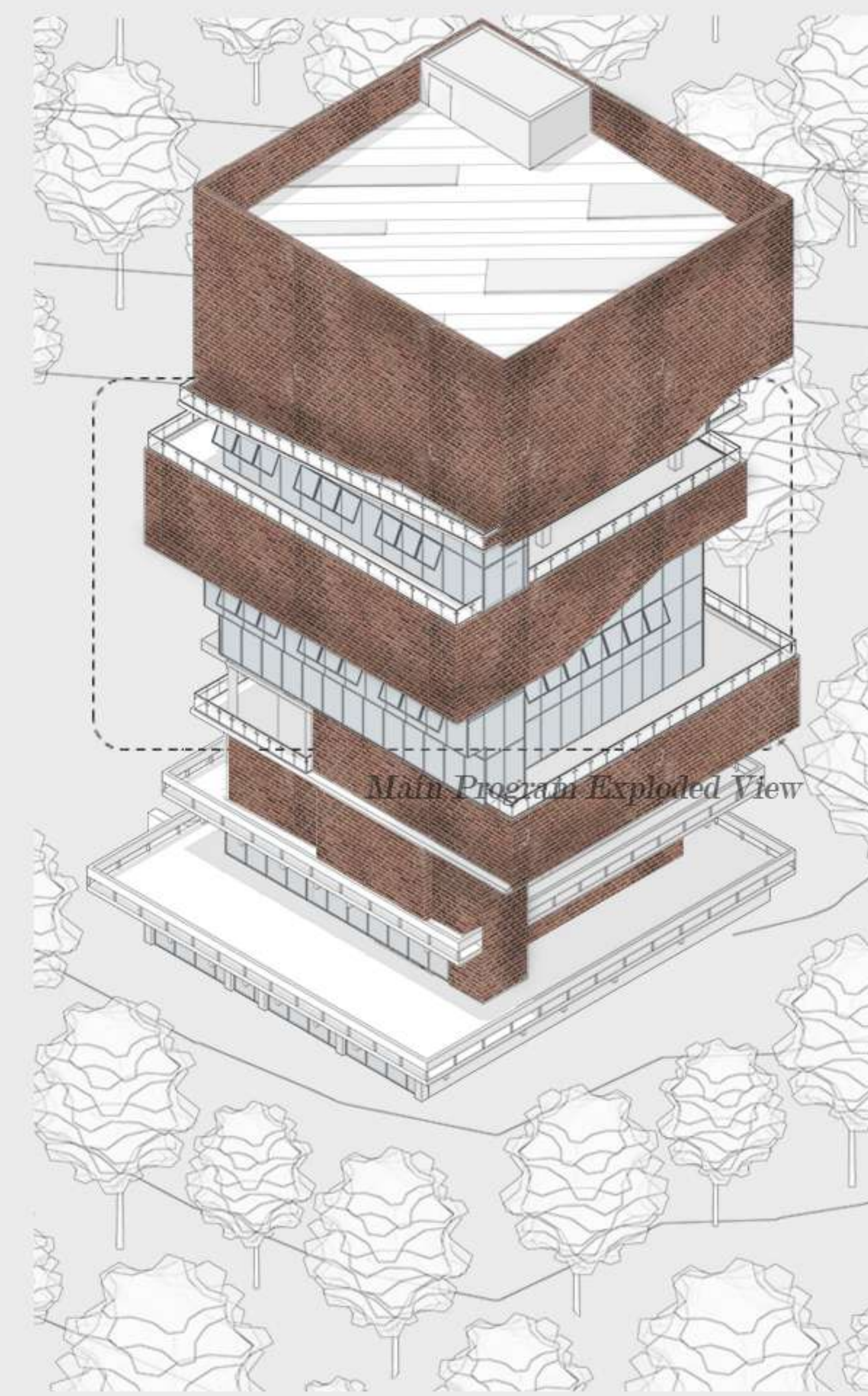

Whole Building

| Programing ; The most important program in the function of the Cultural Center is the acquisition of cultural knowledge and assembly. So I set up a concert hall and a library as the main program. What the two programs have in common is that they can set the type of slab. The stair-shaped slab allows the intentional view to be viewed from within the space. And applied these properties through view analysis.

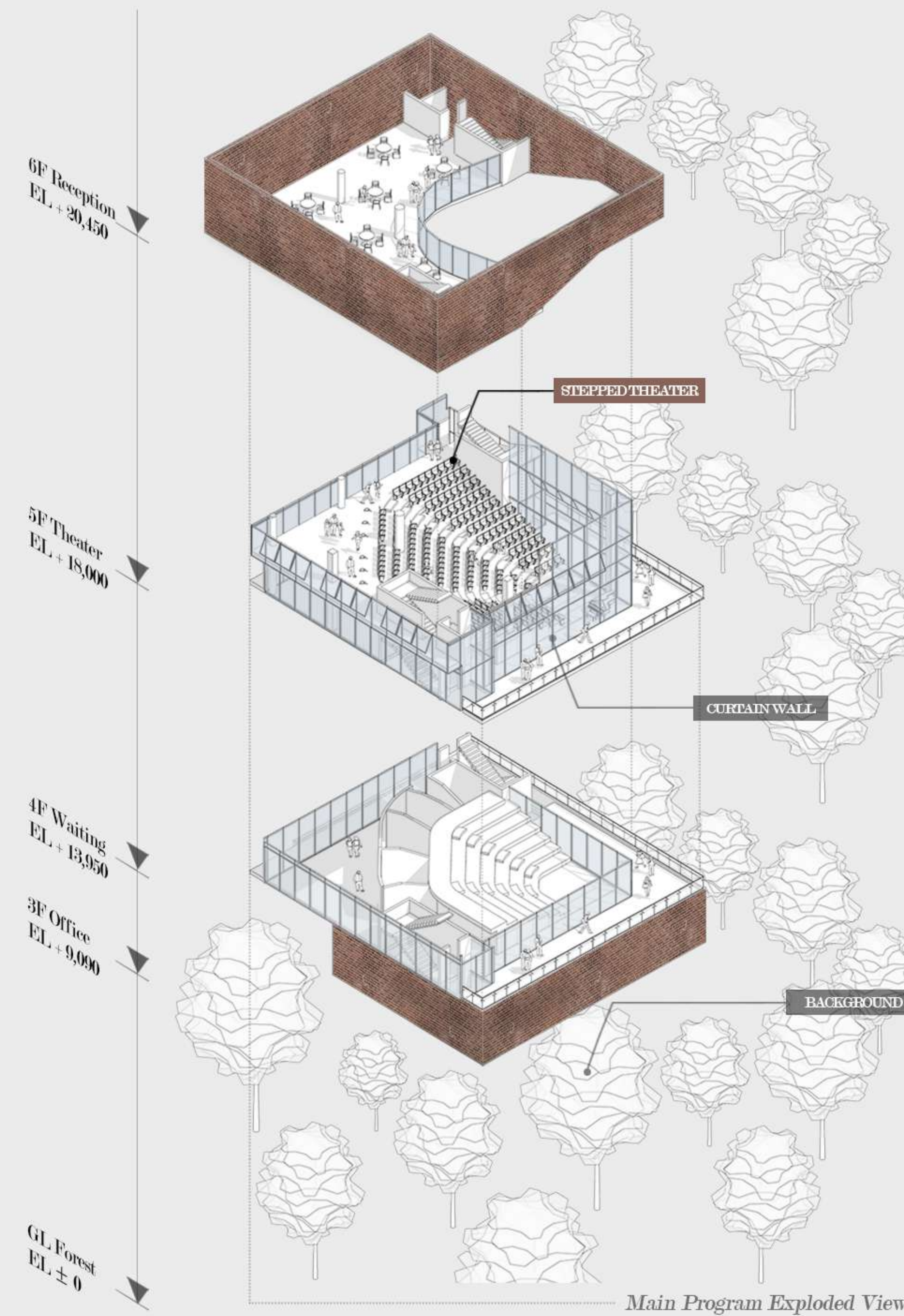

View Analysis by Floor

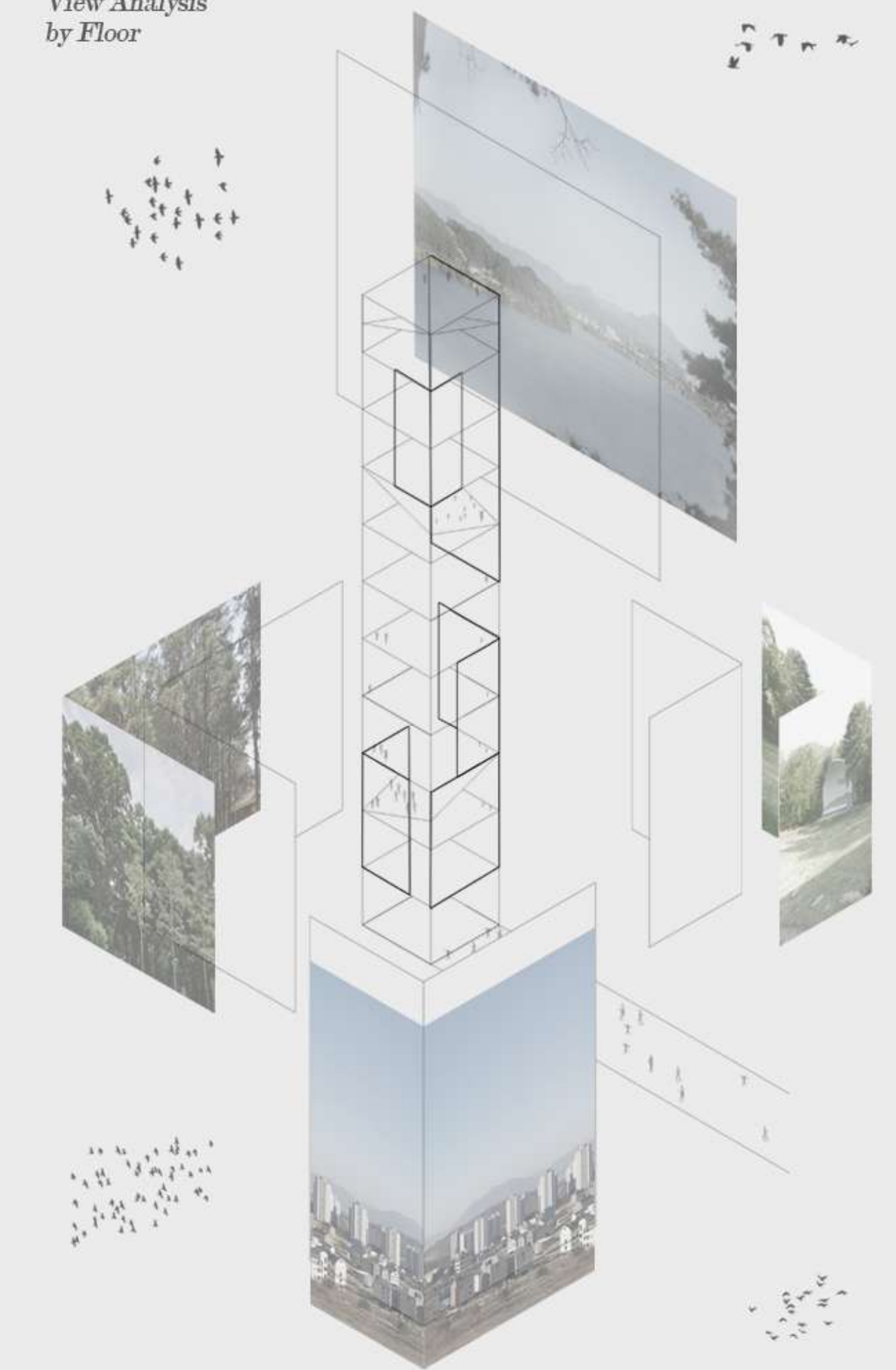

| Viewing Point ; The concept of vertical expansion and the size of the building were established and an analysis was conducted on what landscapes could be seen for each floor. Each program offers views of Green View, River View, City View, and Lawn View. These landscapes provide a background for experiencing each space. And I adjusted the direction of the slab so that I could see the scenery well.

Chungju Cultural Center Remodeling

Viewing Point Plan

- Background for Program

| a Static City ; Benny This shit got me in my feelings Gotta be real with it, yup Kiki, do you love me? Are you rTrap, TrapMoneyBenny This shit got me in my feelings Gotta be real with it, yup Kiki, do you love me? Trap, TrapMove me? Are you rTrap, TrapMoneyBenny This shit got me in my feelings Gotta be real with it, yup Kiki, do you love me? Trap, TrapMo ney

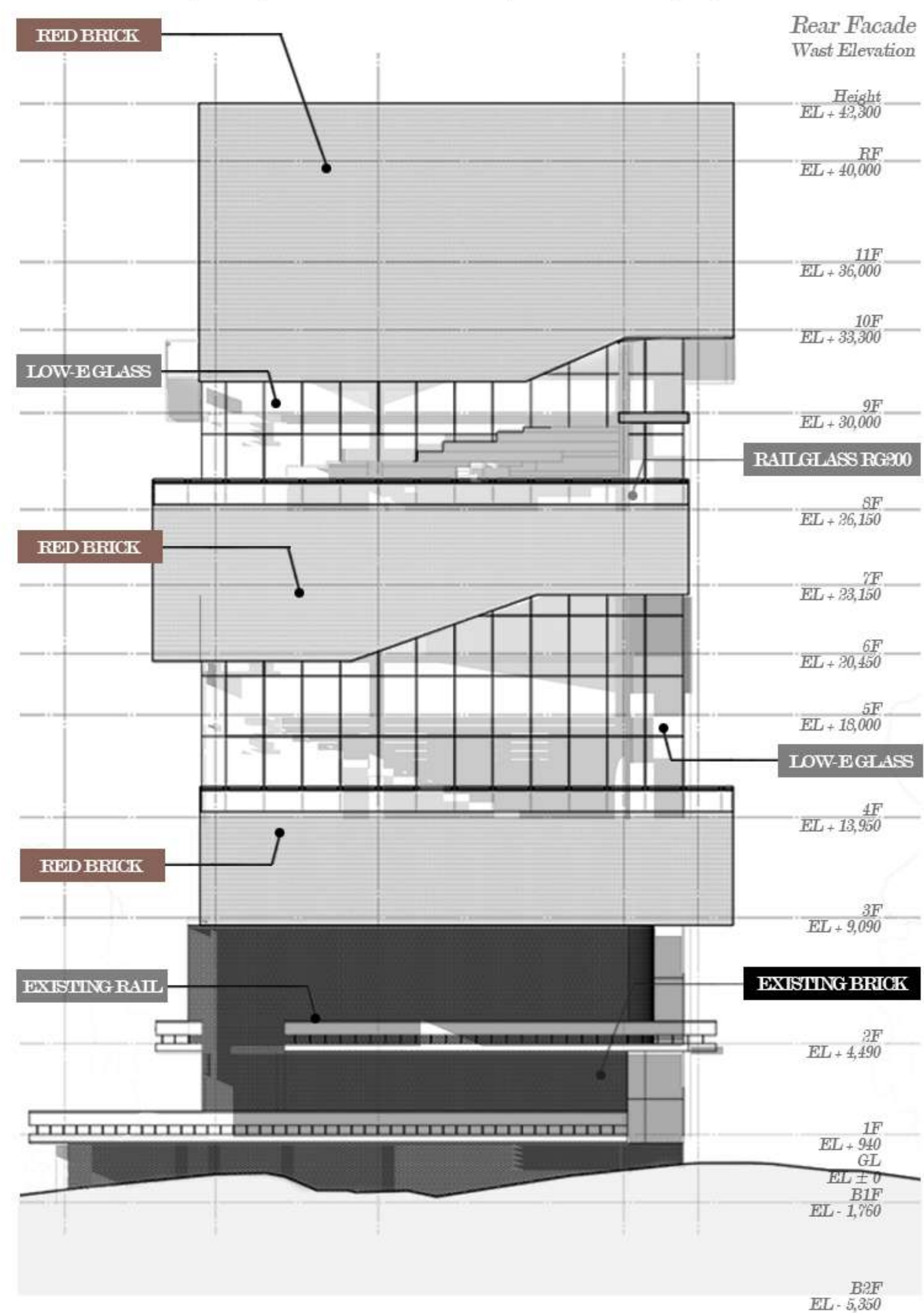
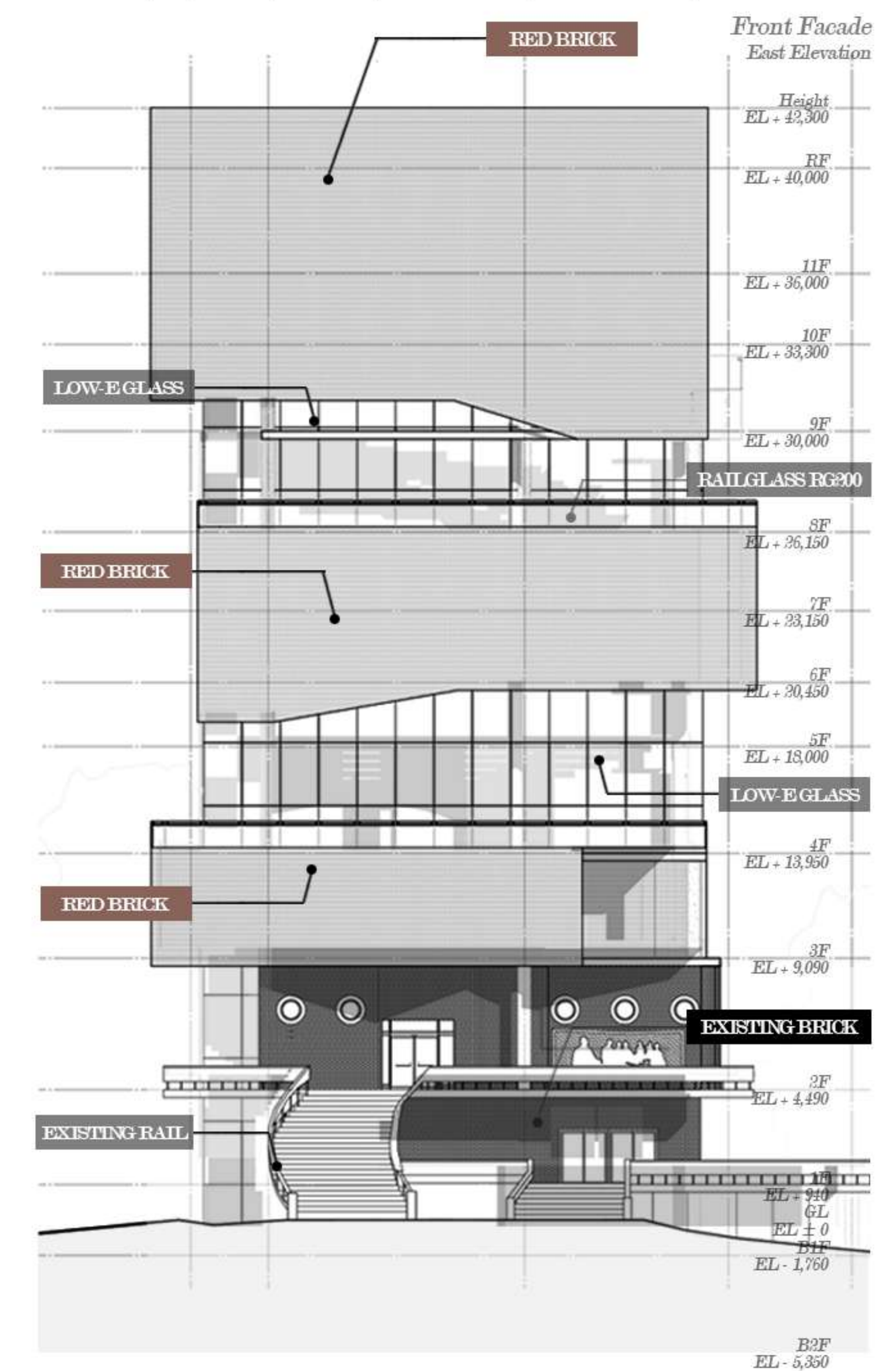
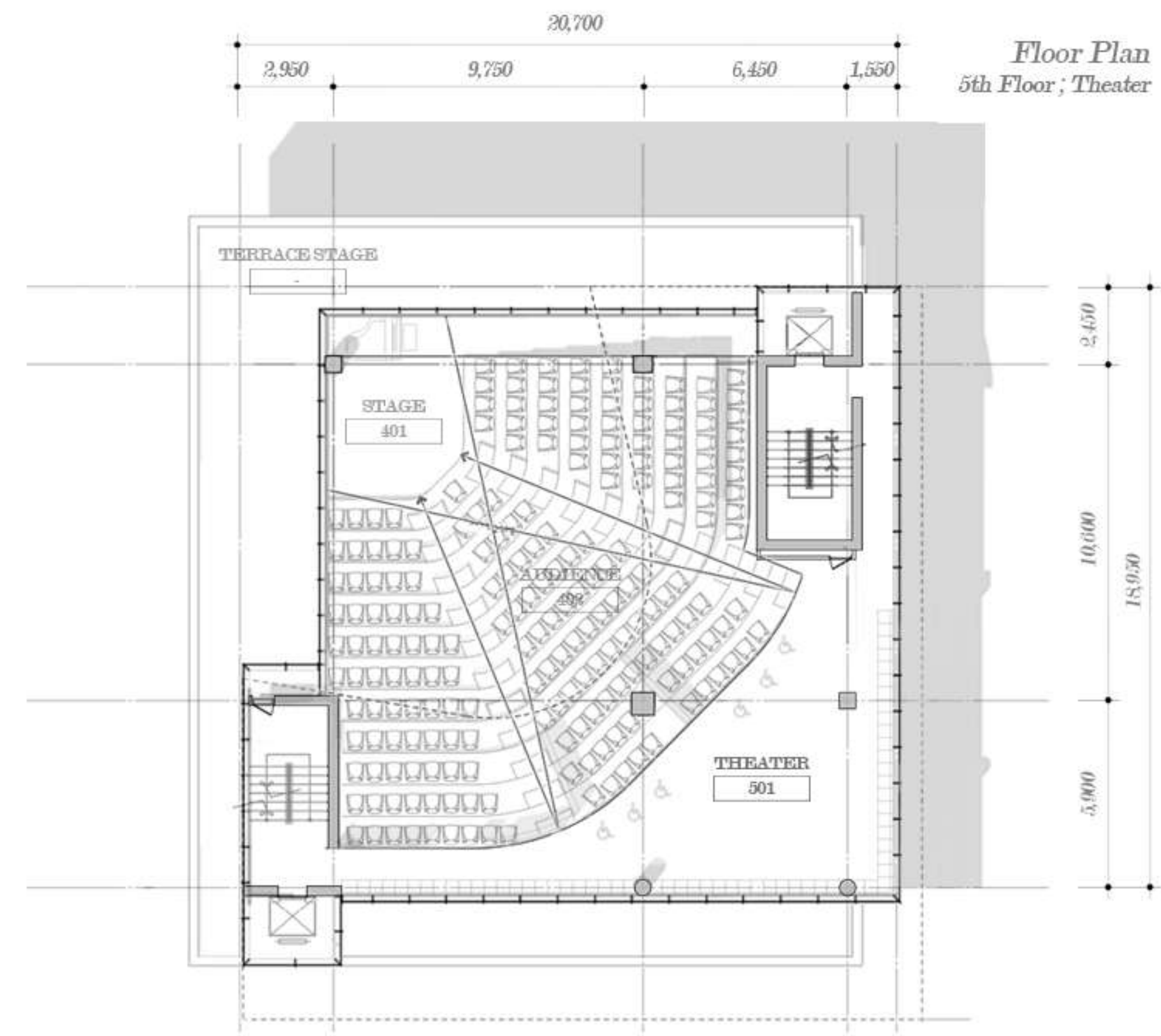
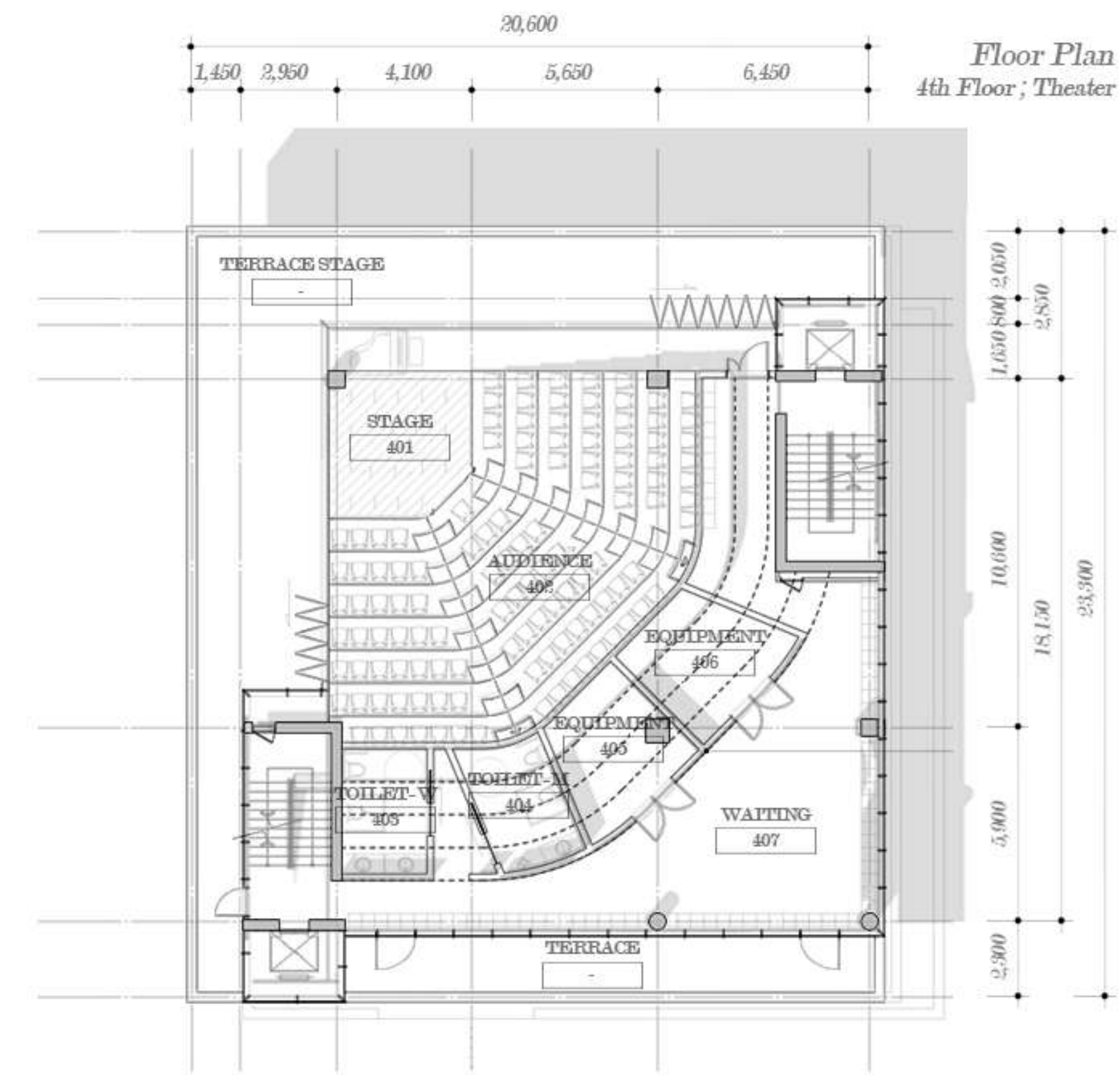
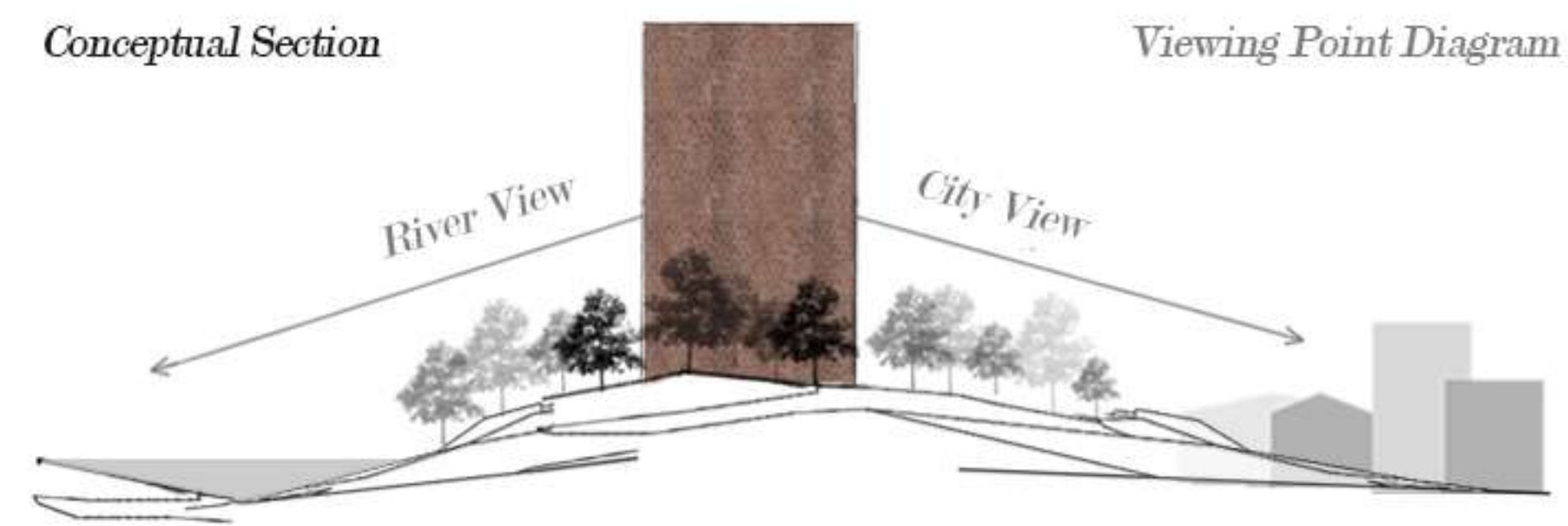

Sectional Model



Brick Finish

- Facade of Chungju Cultural Center

Brick Facade ; One of the characteristics of the existing Chungju Cultural Center building is the exterior of red bricks. It has a symbolic red brick facade that holds the time of Chungju Cultural Center. I preserved the exterior of the existing building. The newly expanded building reflects the new time at Chungju Cultural Center using red brick exterior materials. Red brick will now symbolize Chungju Cultural Center and become a medium for remembering Tangeumdae.

I studied the details of the red brick finish and applied it to this project. The study of insulation was included, and an external insulation system was applied. The drawings below are part of the detailed information of the outer wall cross section investigated.

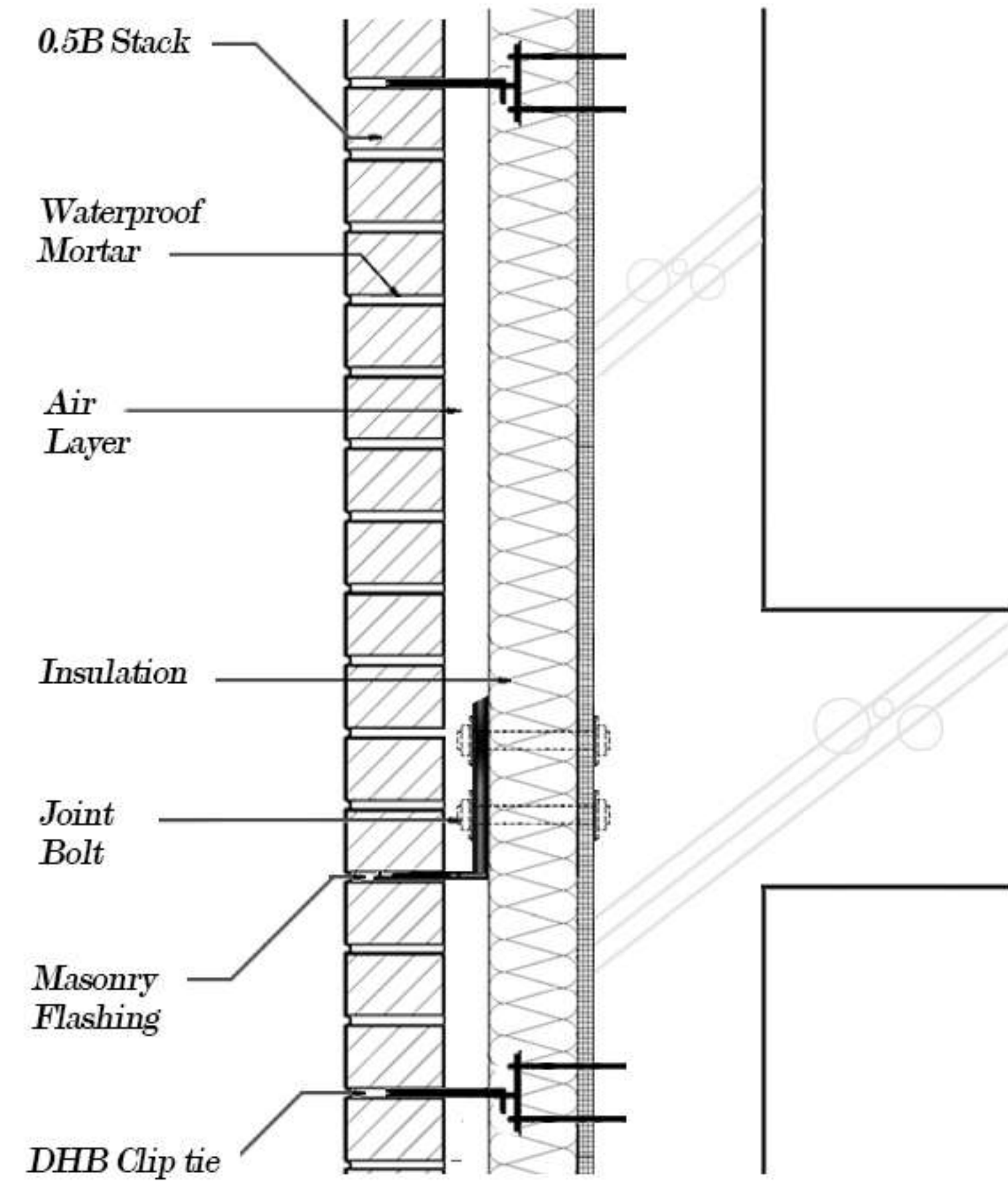

Brick Wall Sectional Detail

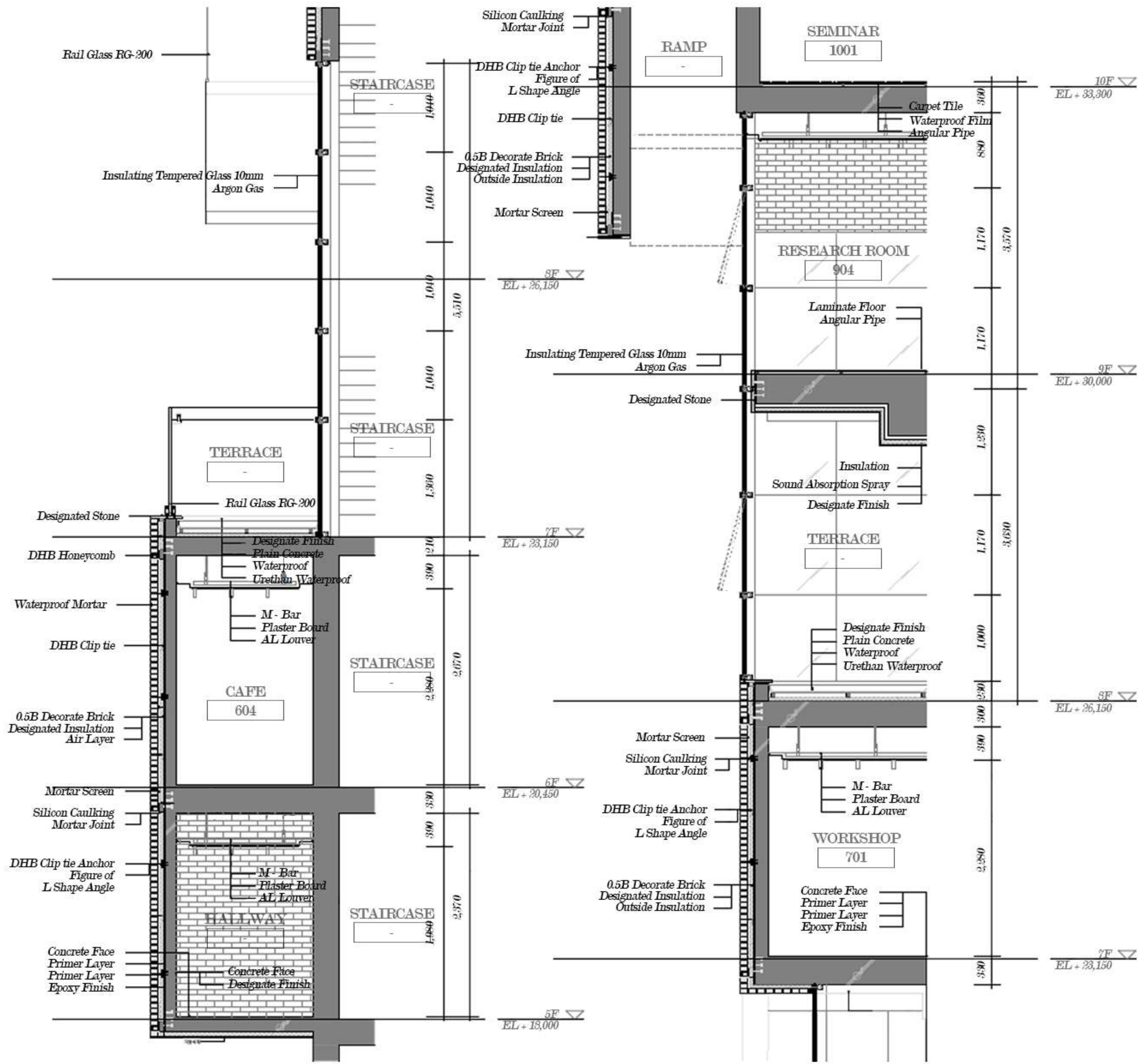

Exterior Wall Section Detail 1

Exterior Wall Section Detail 2

Detailed Drawing

- Finishing Detailed drawing

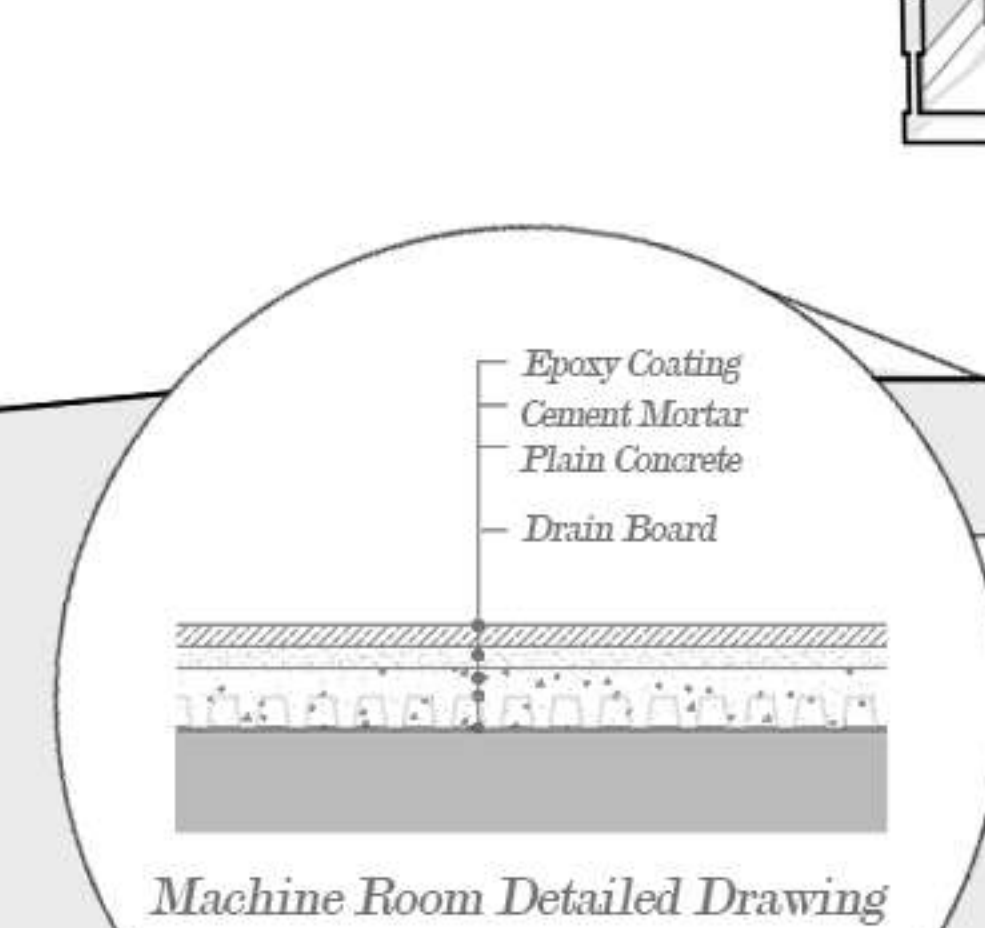
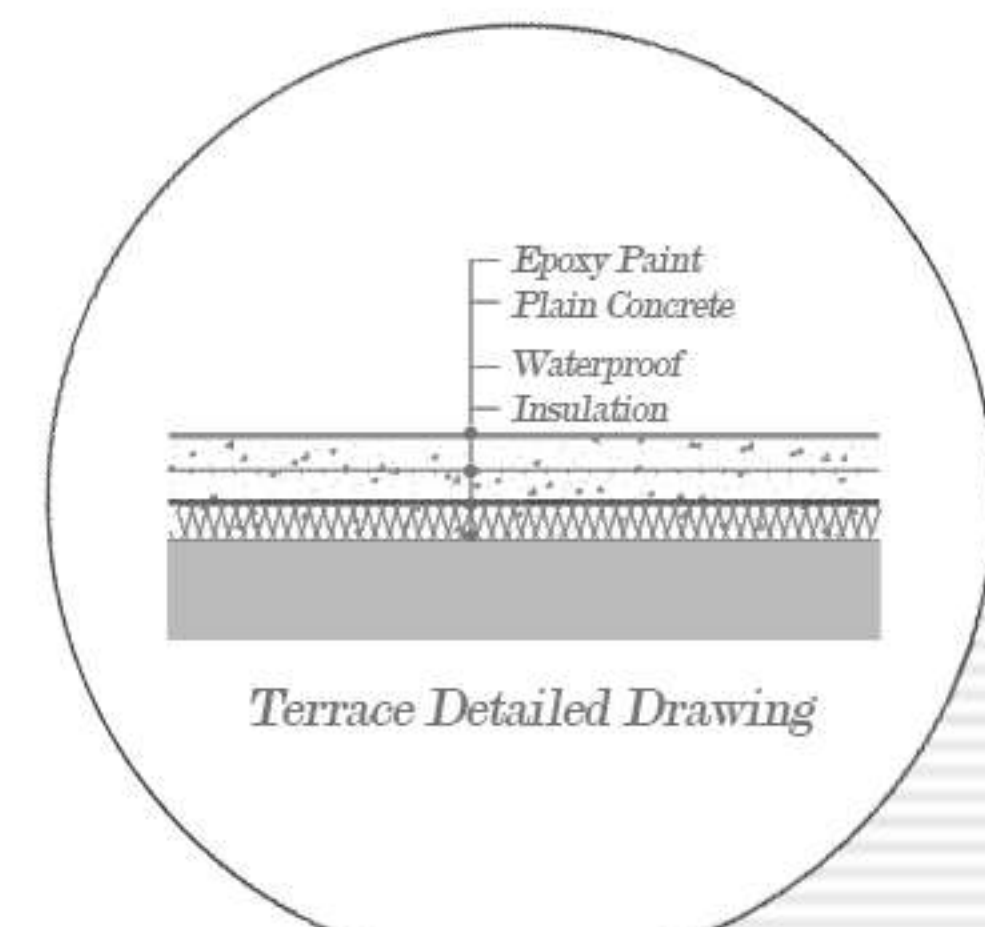
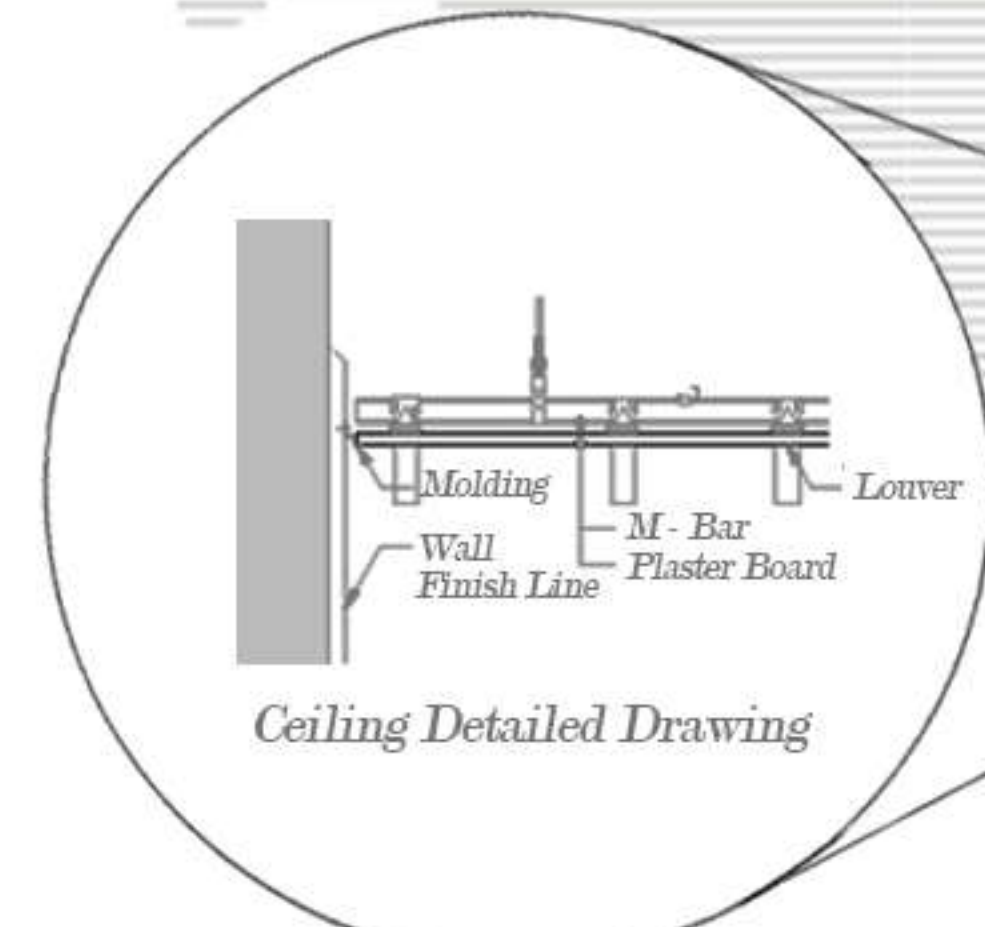
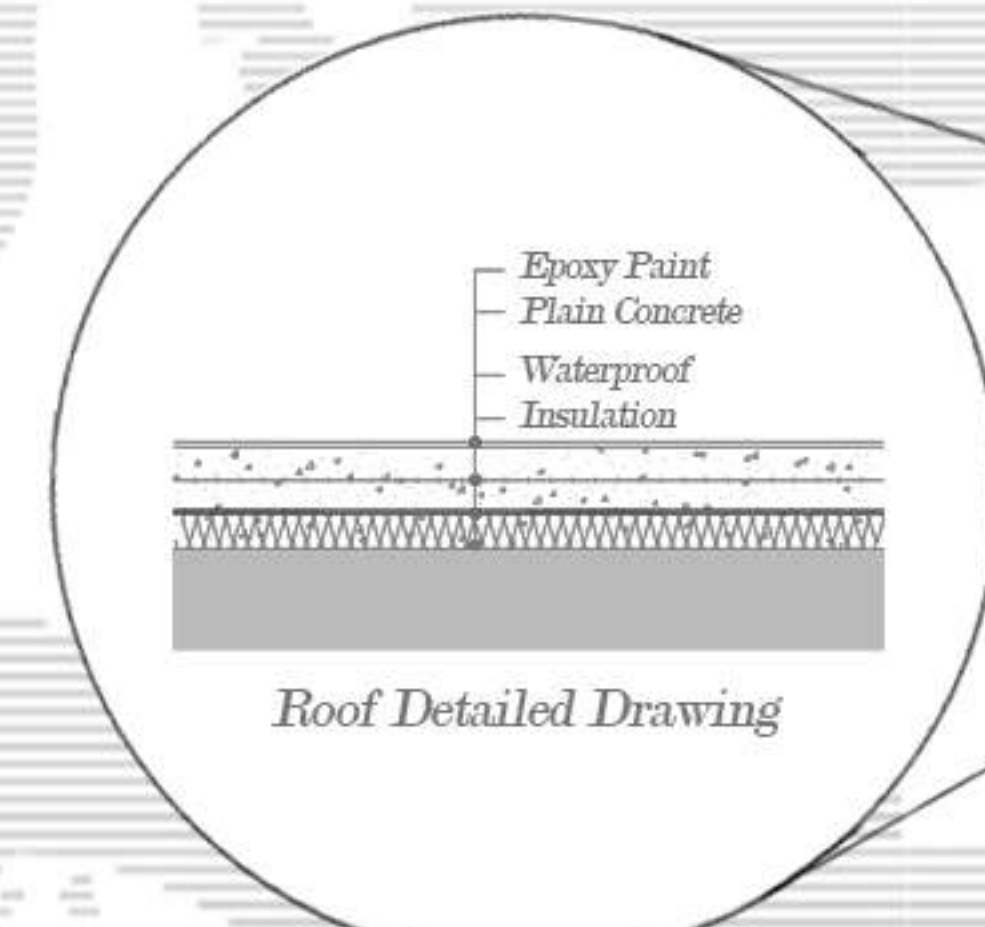

Finishing Study ; Due to the small size of the project building, I wanted to conduct a study on finishing details and improve the perfection of the project. The study's finishing details are expressed in sectional perspective below.

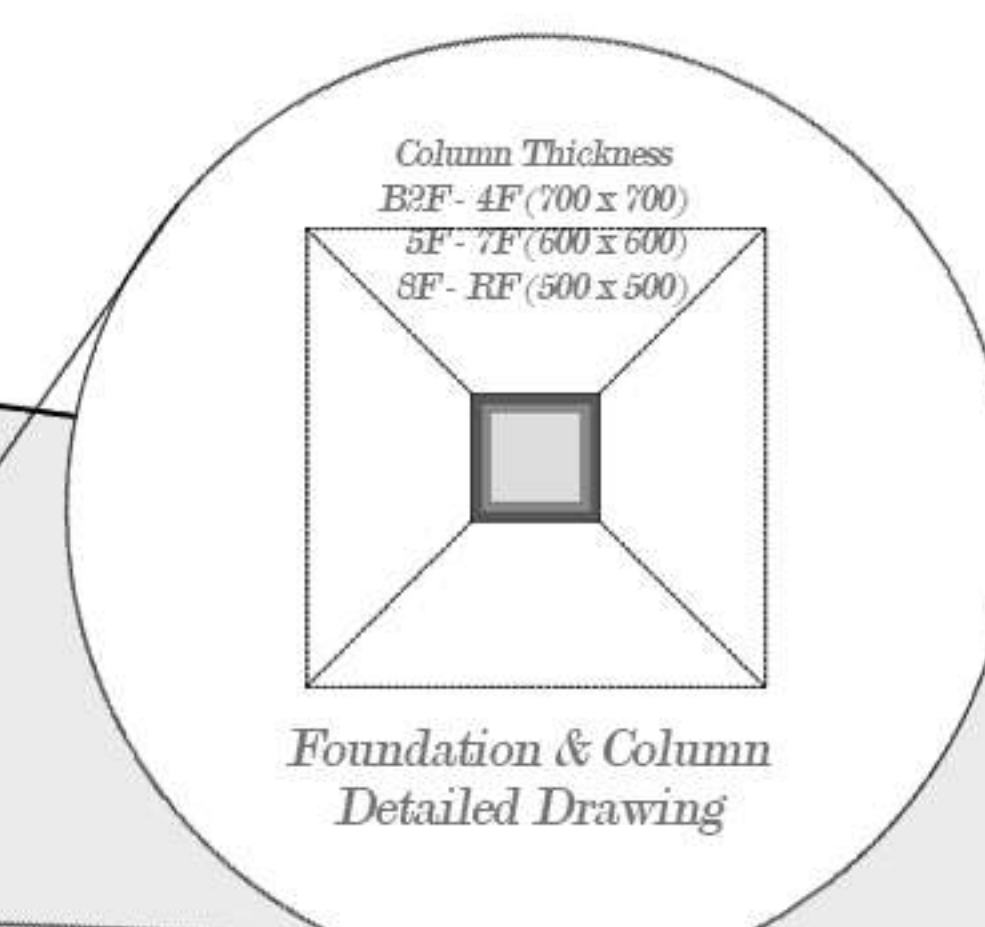
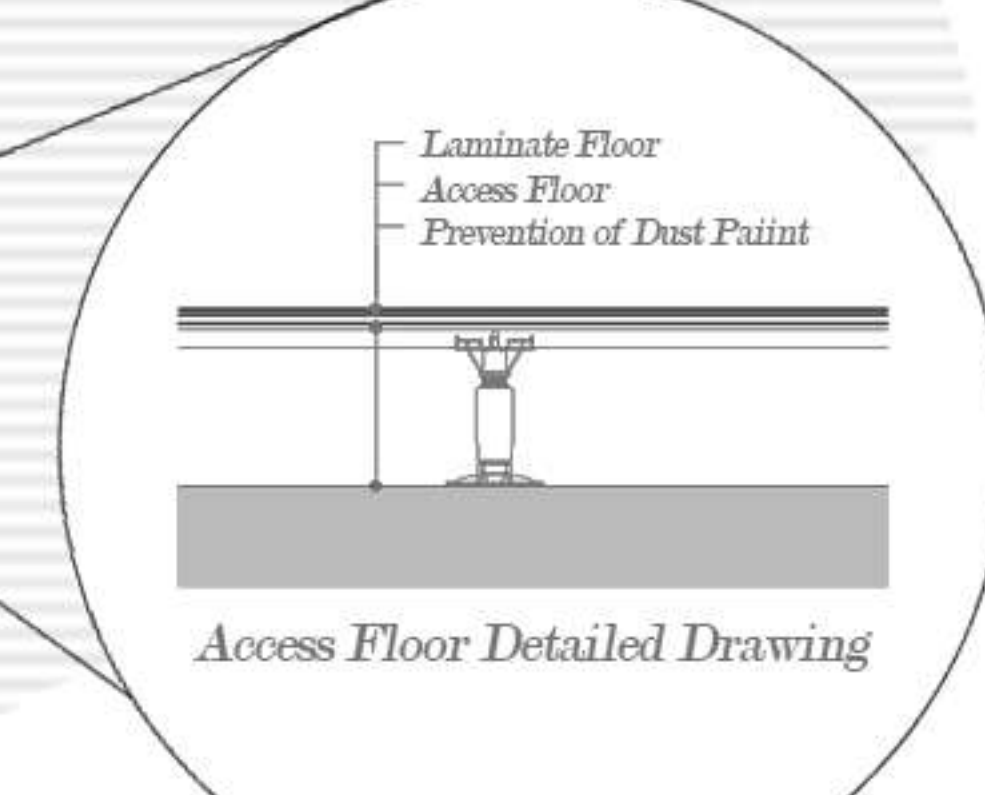
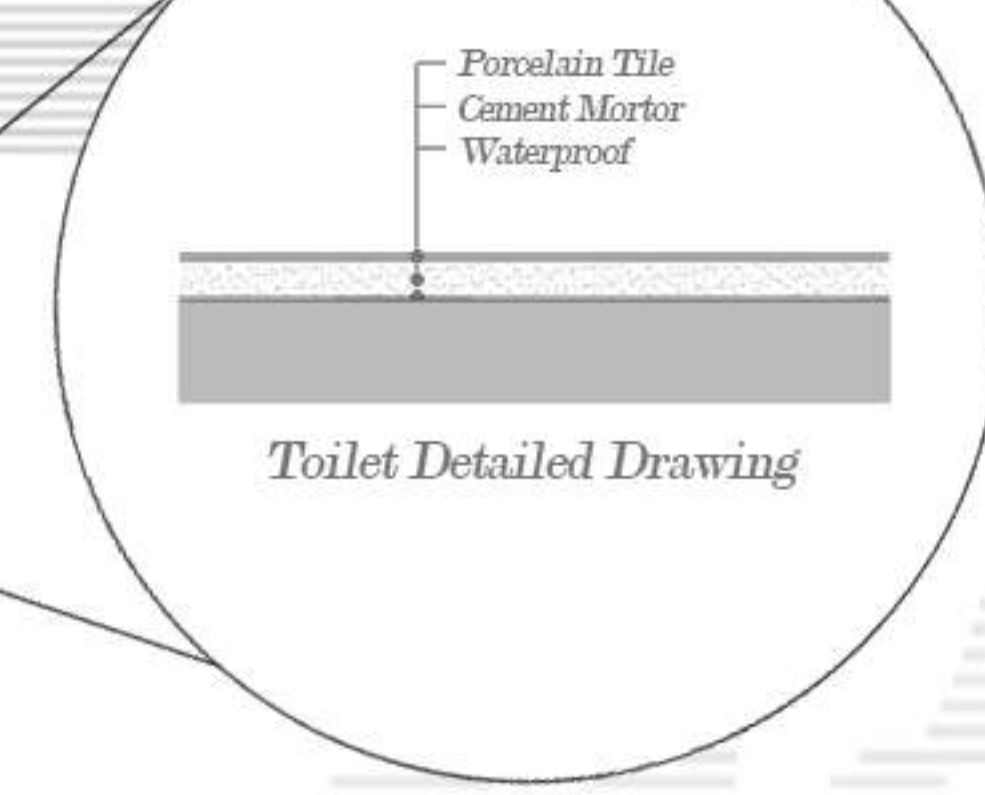
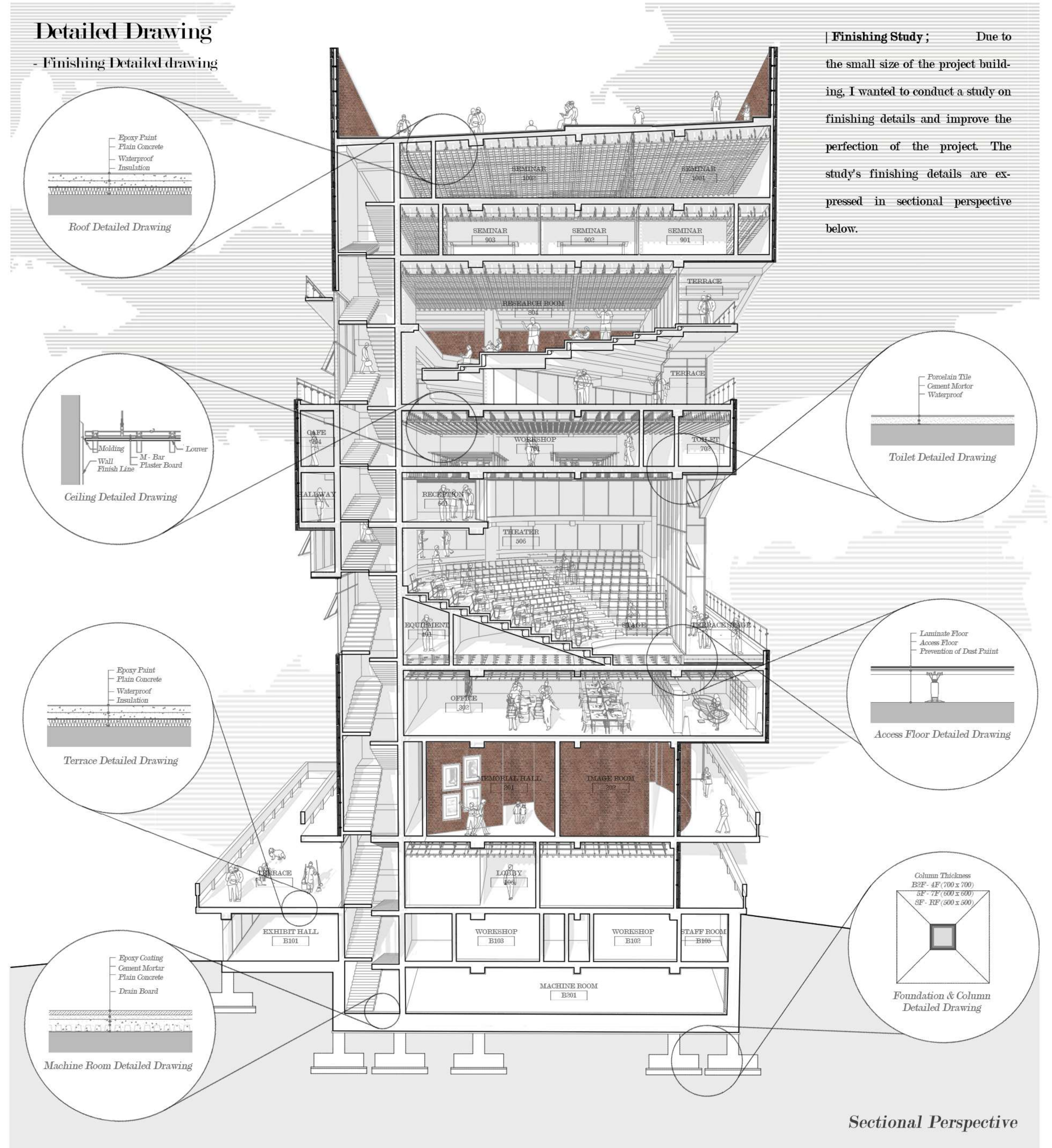

Sectional Perspective

Alleyway Theater

- Chungju Cultural Complex Project

Partial Model



| Stair Design ; Alleyways with an old-fashioned atmosphere can be a spectacle in themselves. The project is an alley theater where visitors can watch the activities of people who use the alley. Because several theaters need to be built, a large number of stairs are needed. The stairs are designed to be used as louver to bring natural light into underground and indoor spaces. In order to control the amount of light, the shadow analysis below was carried out, and the stairway specifications were adjusted as needed.

Shadow Analysis

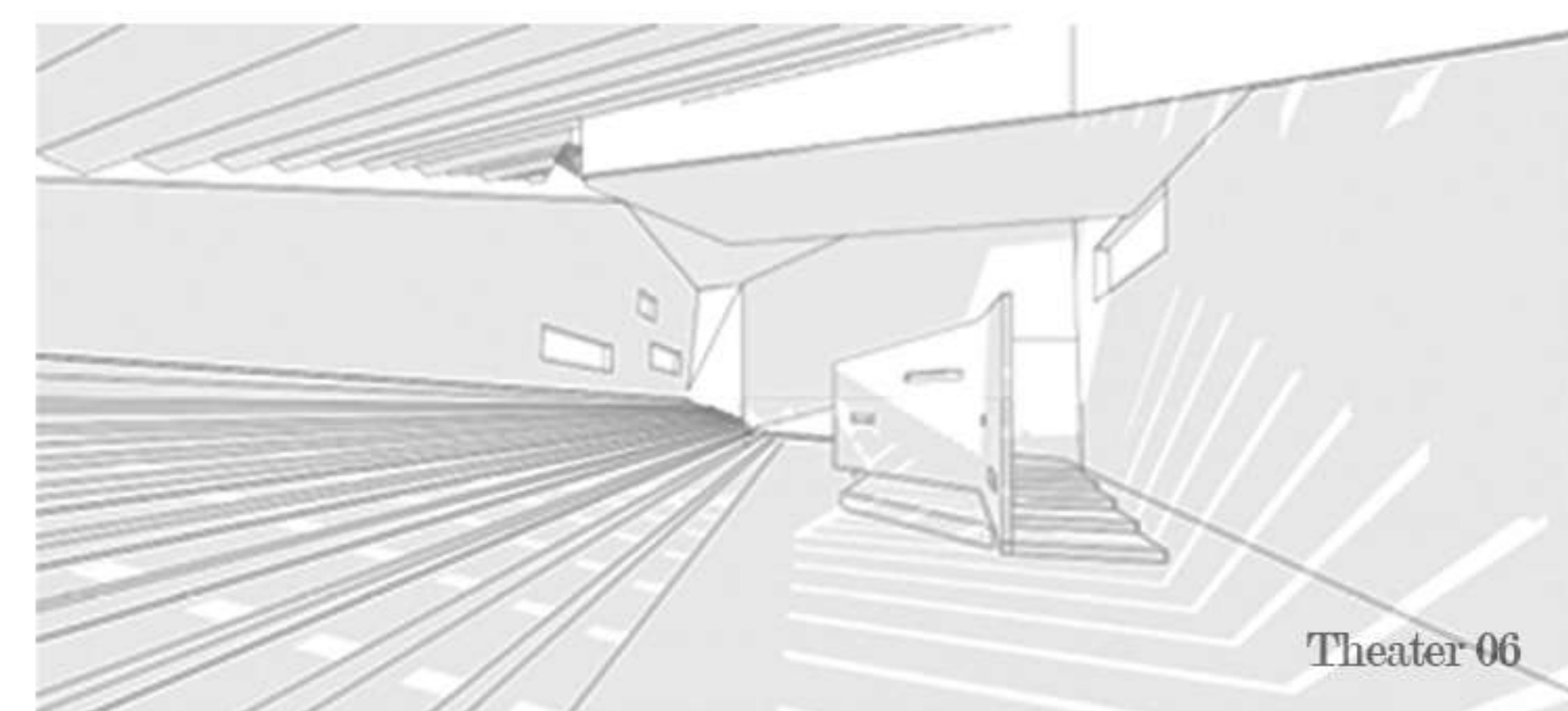
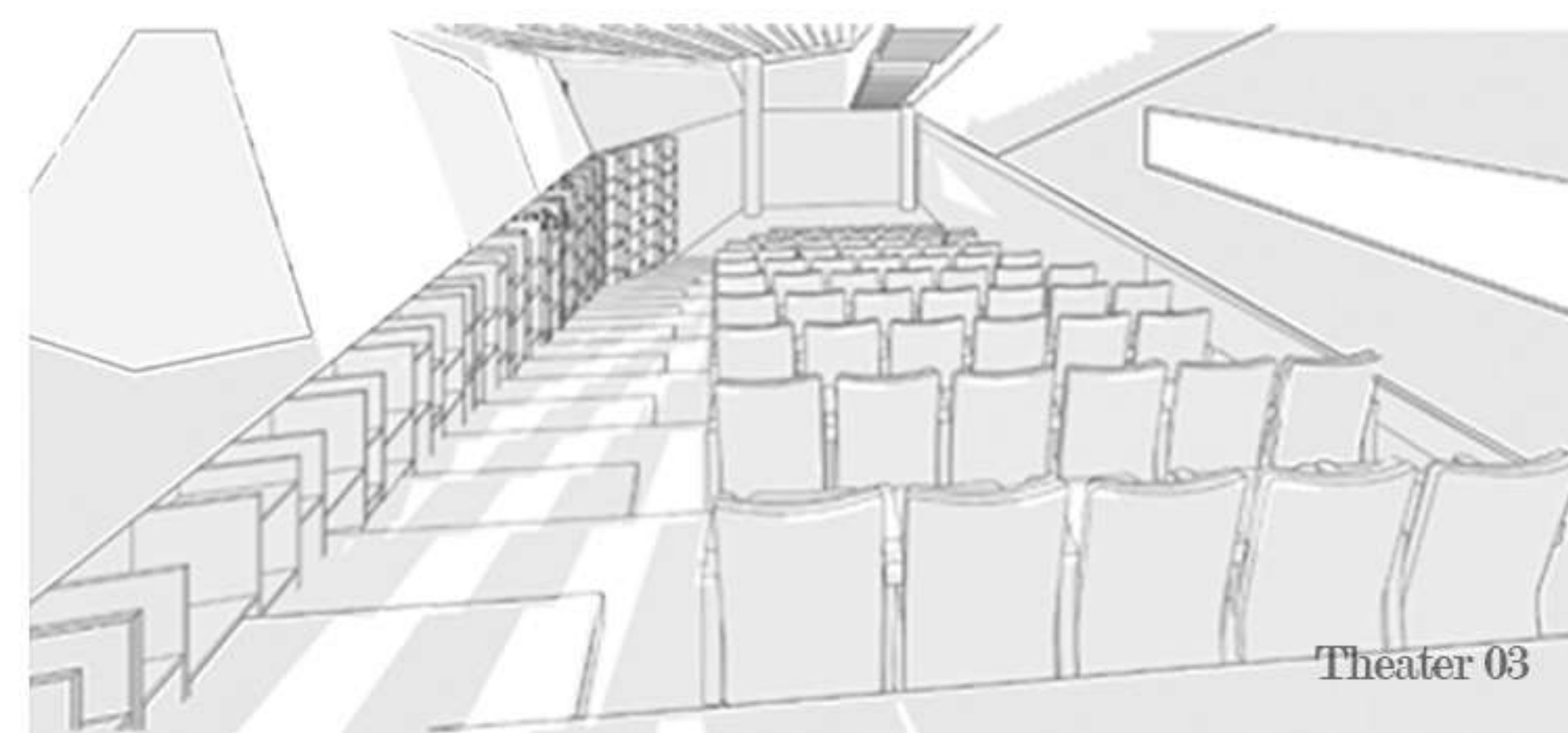

Sectional Perspective

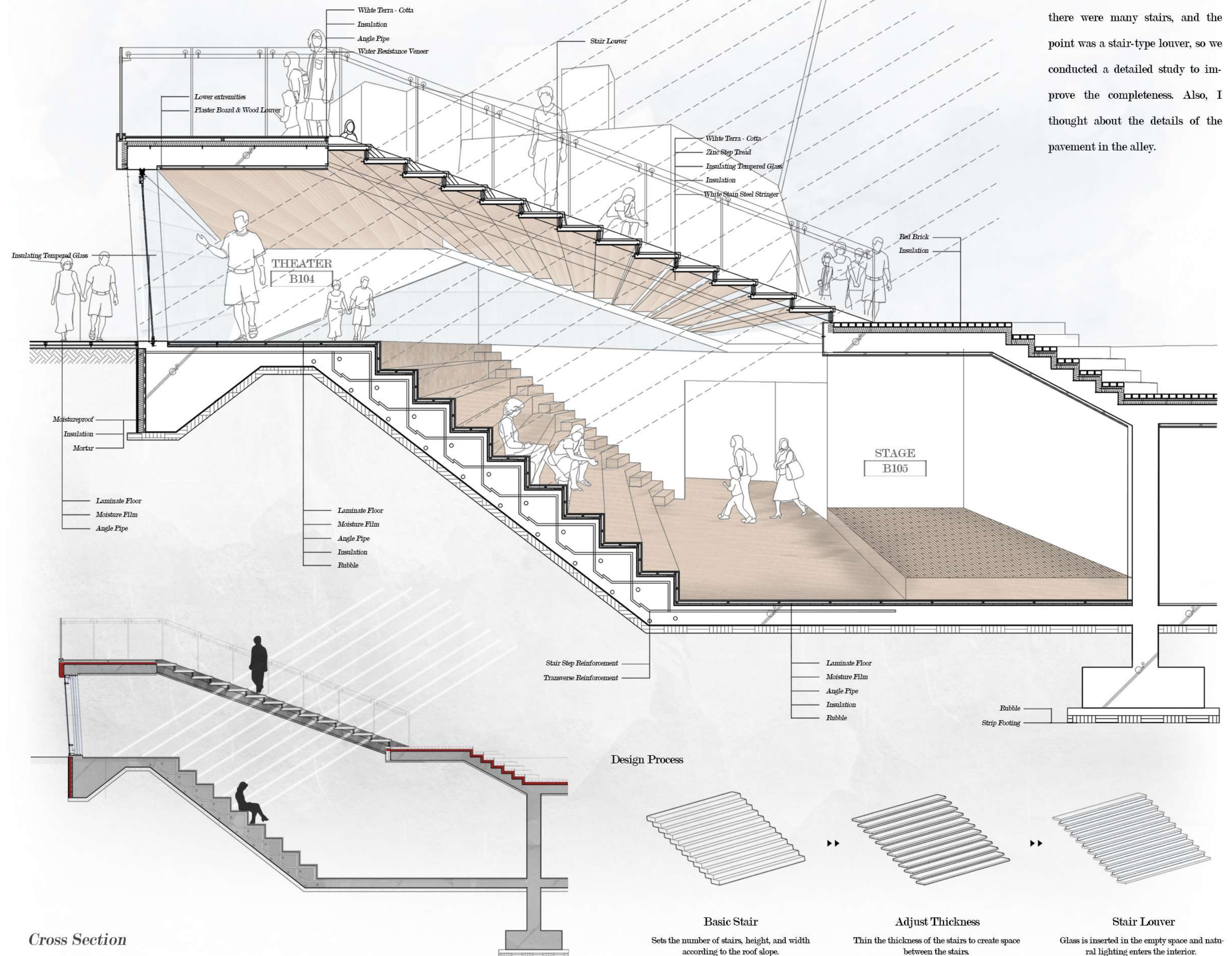

Cross Section

Design Process

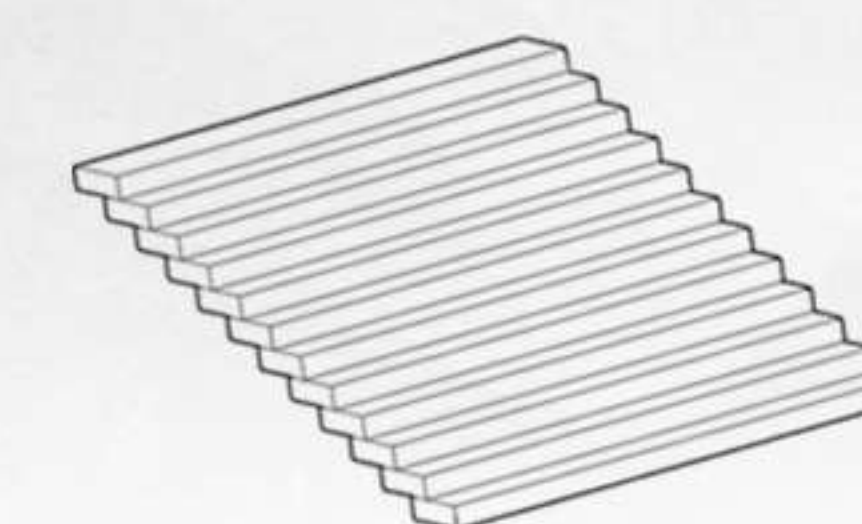

Basic Stair
Sets the number of stairs, height, and width according to the roof slope.

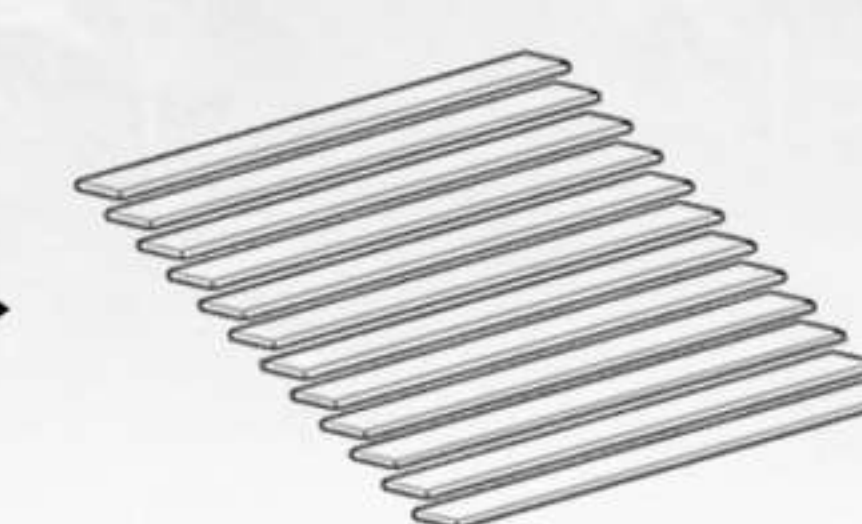

Adjust Thickness
Thin the thickness of the stairs to create space between the stairs.

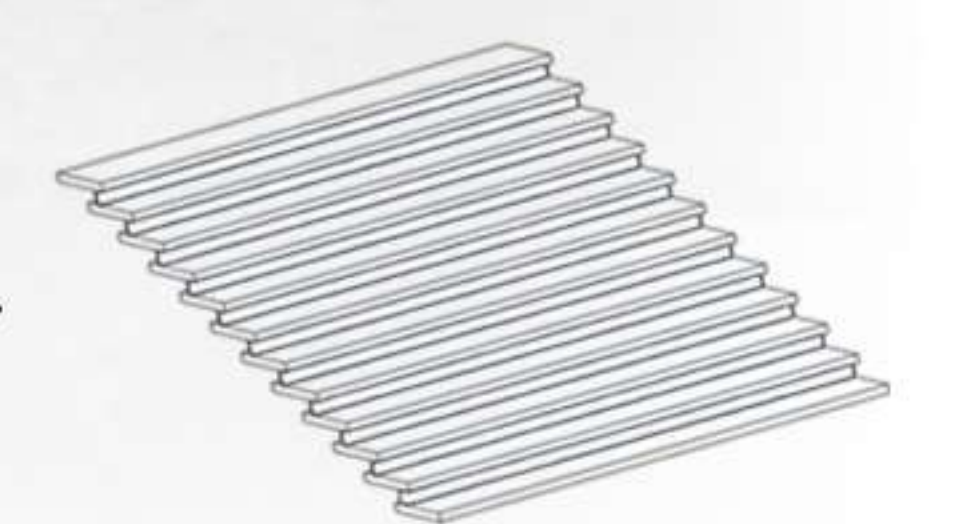

Stair Louver
Glass is inserted in the empty space and natural lighting enters the interior.

Individual Project

| Detail Study ; Due to the nature of the concert hall project, there were many stairs, and the point was a stair-type louver, so we conducted a detailed study to improve the completeness. Also, I thought about the details of the pavement in the alley.

BIM Challenge

- Lotte Tower Information Modeling & Visualization

Individual Project

Structure Summary

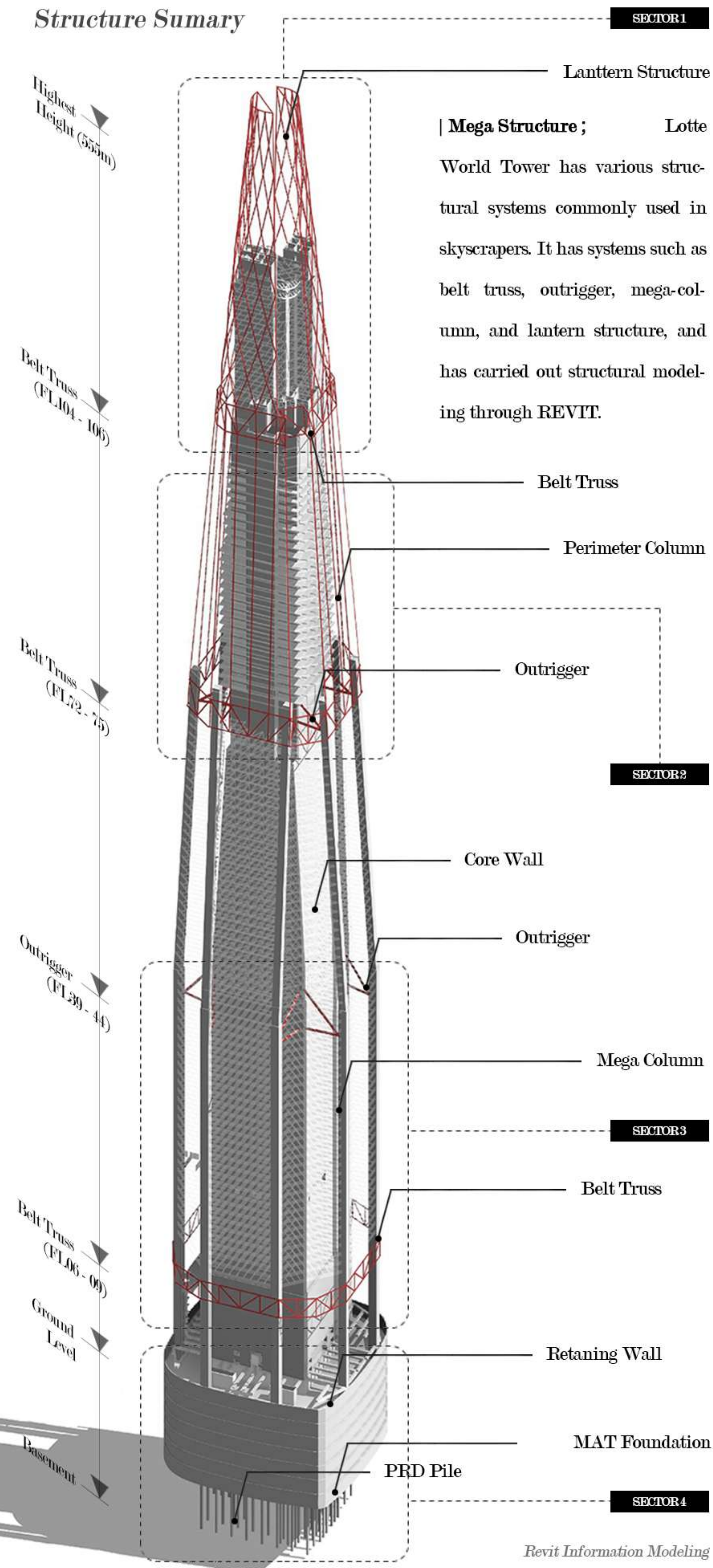

Revit Information Modeling

| Pattern Base Family ; Lotte World Tower is divided into four buildings, including an ultra-high-rise tower. Each dong has a different form of facade and used pattern-based modeling to implement these facade. The mass was modeled using an 'internal-mass' function.

The following families are part of the facade pattern used primarily in each building. In addition to modeling of the REVIT families, we set parameters so that the dimensions of the families can be adjusted as needed. These families were applied through surface segmentation of mass.

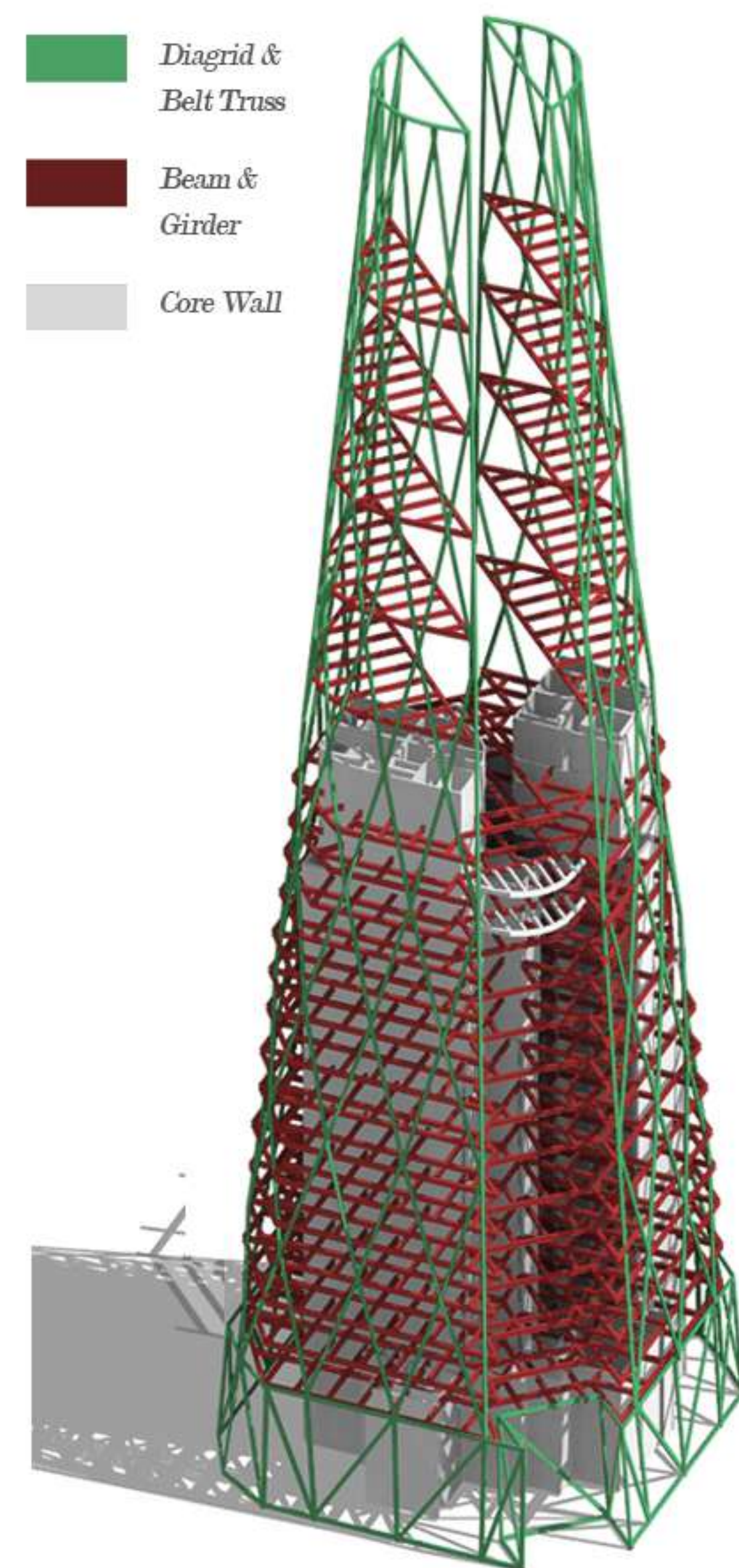
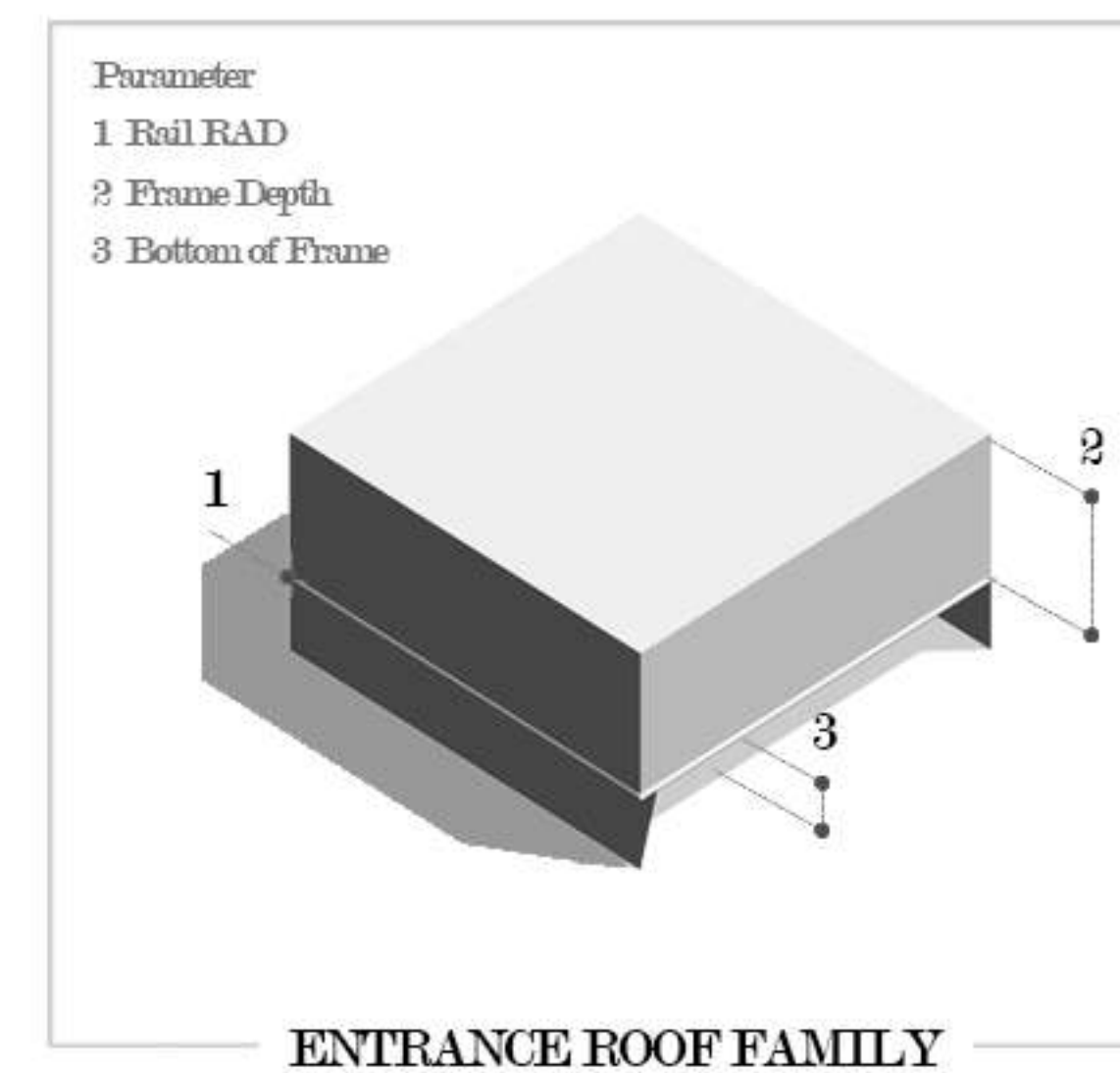
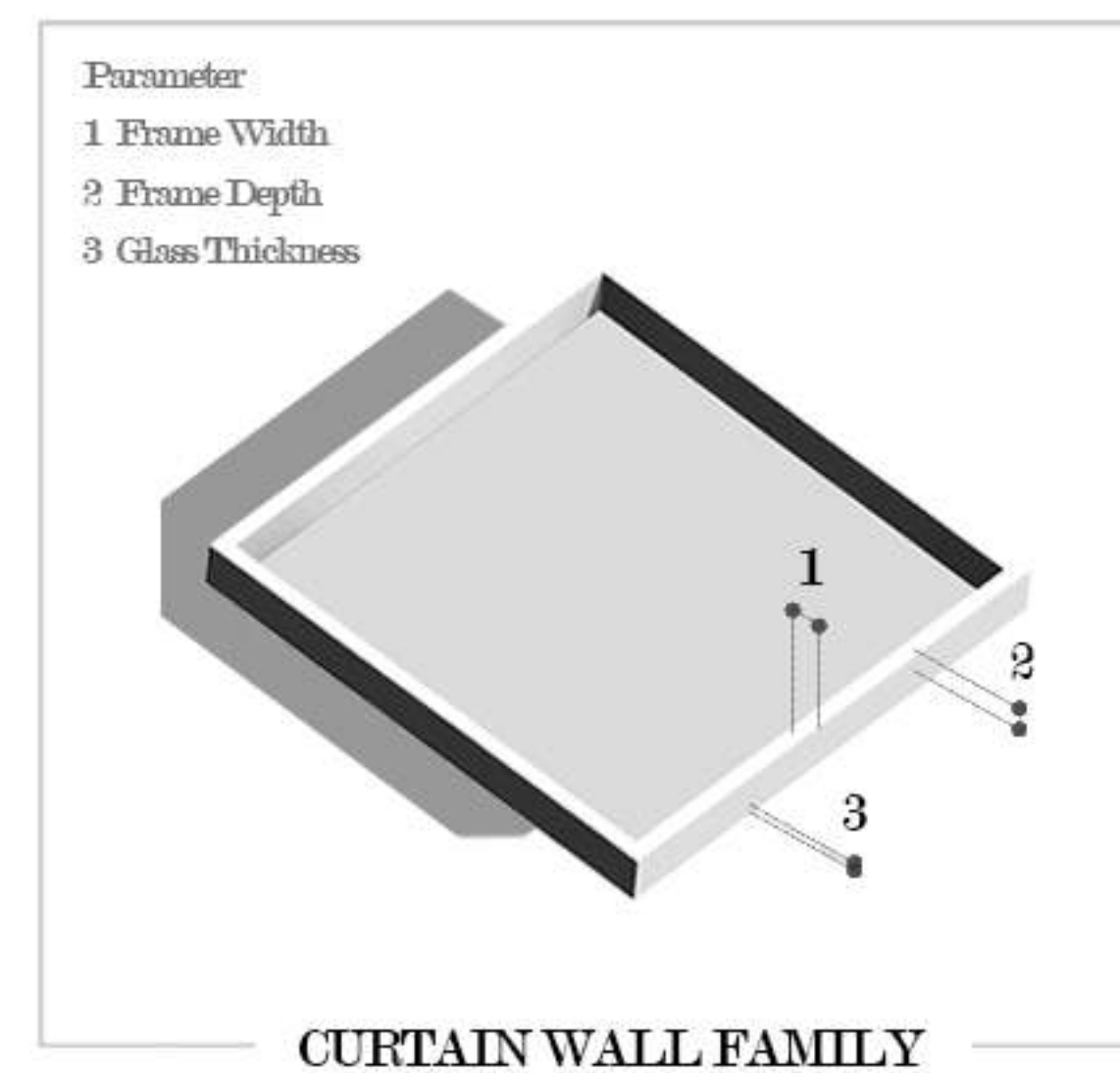
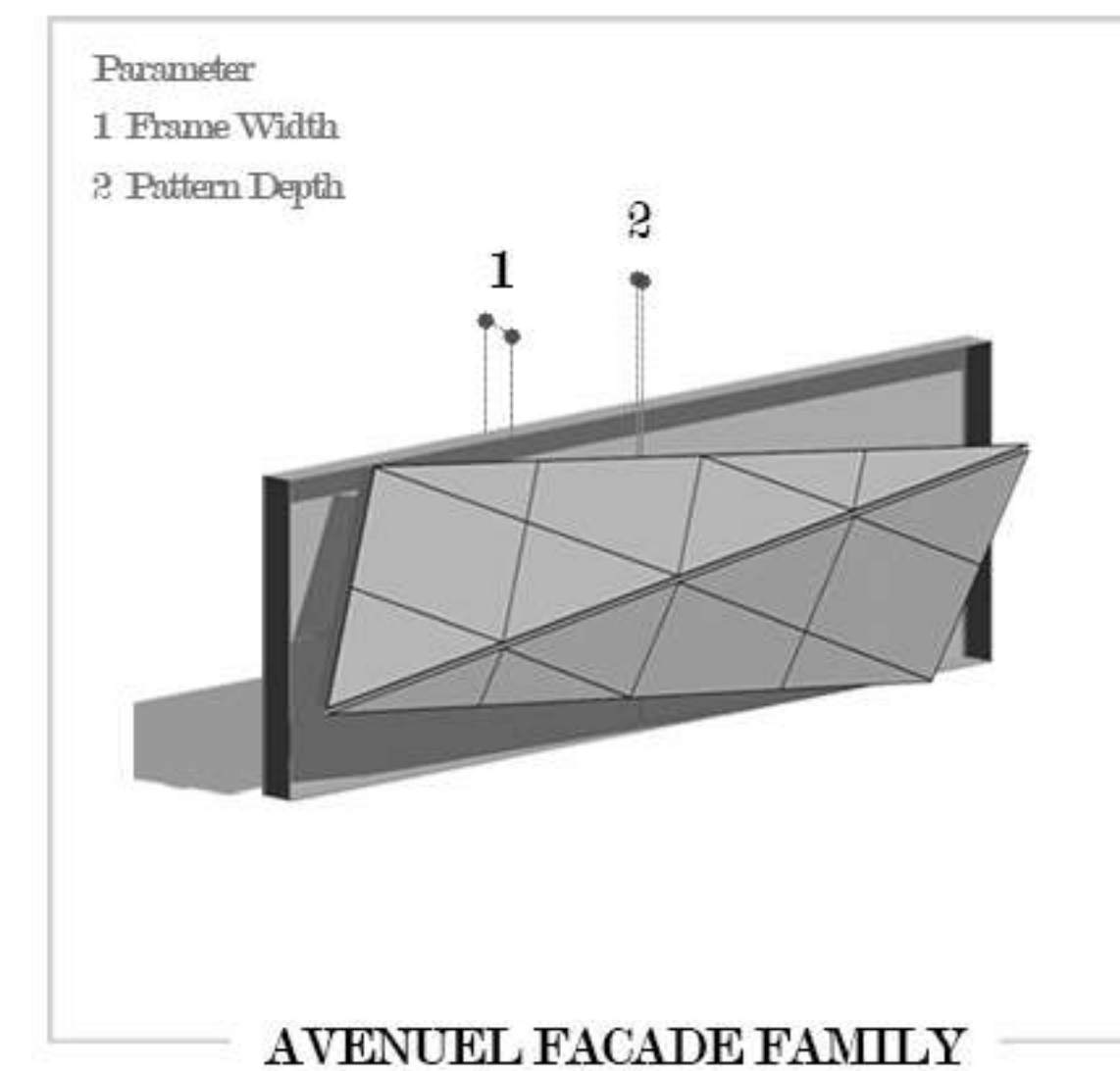
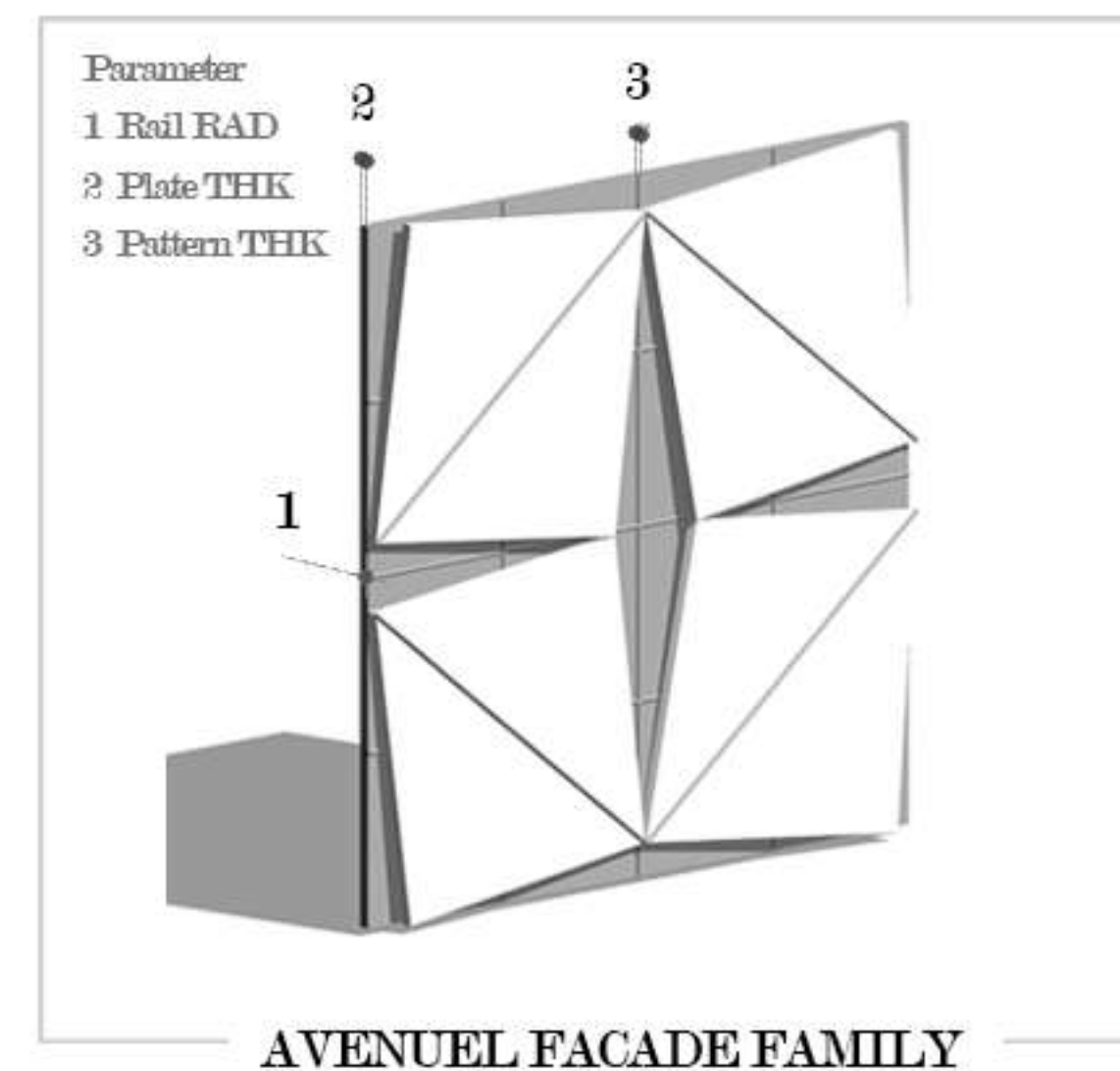

SECTOR 1 : Lantern Structure

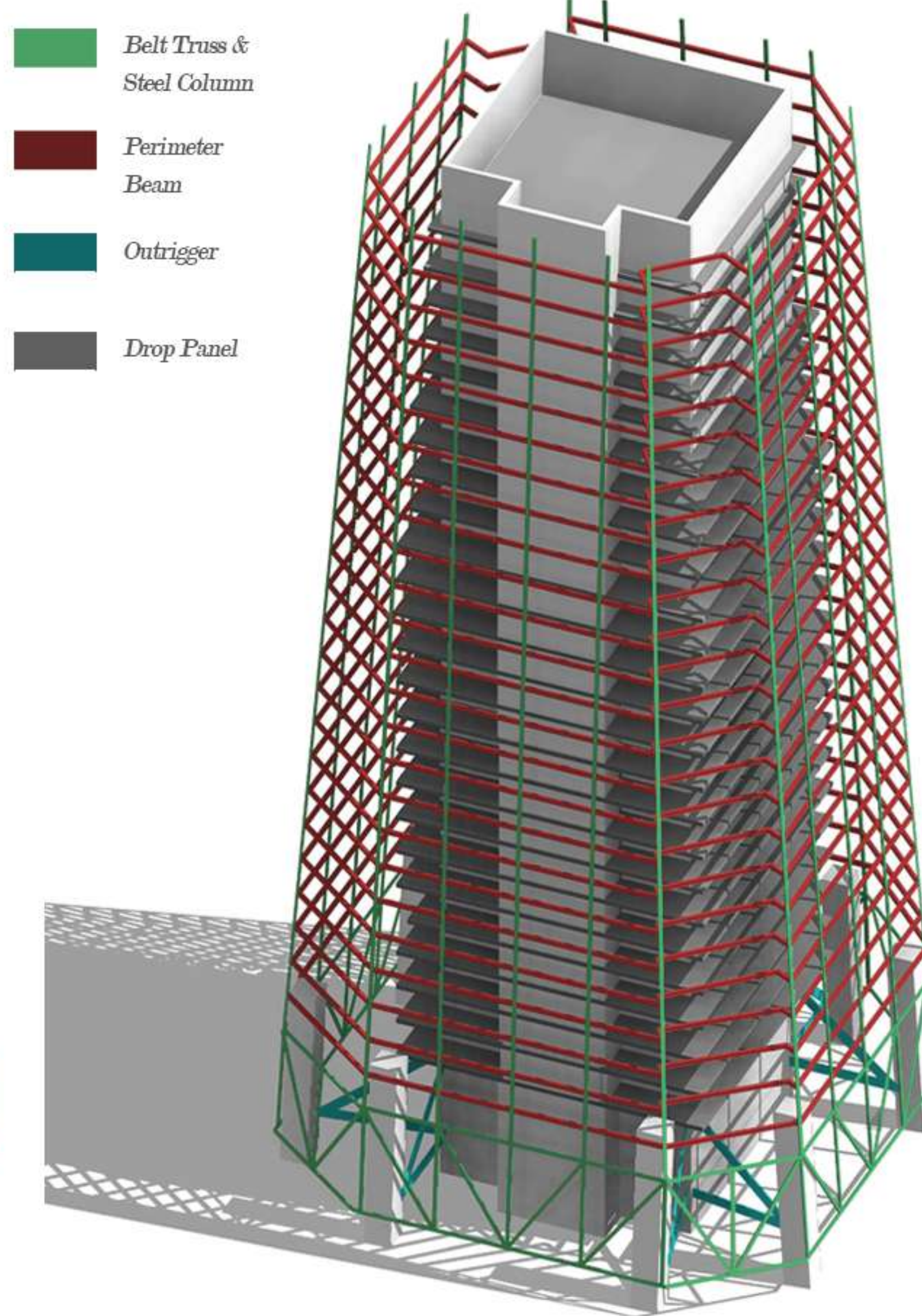

SECTOR 2 : Belt Truss & Outrigger Structure

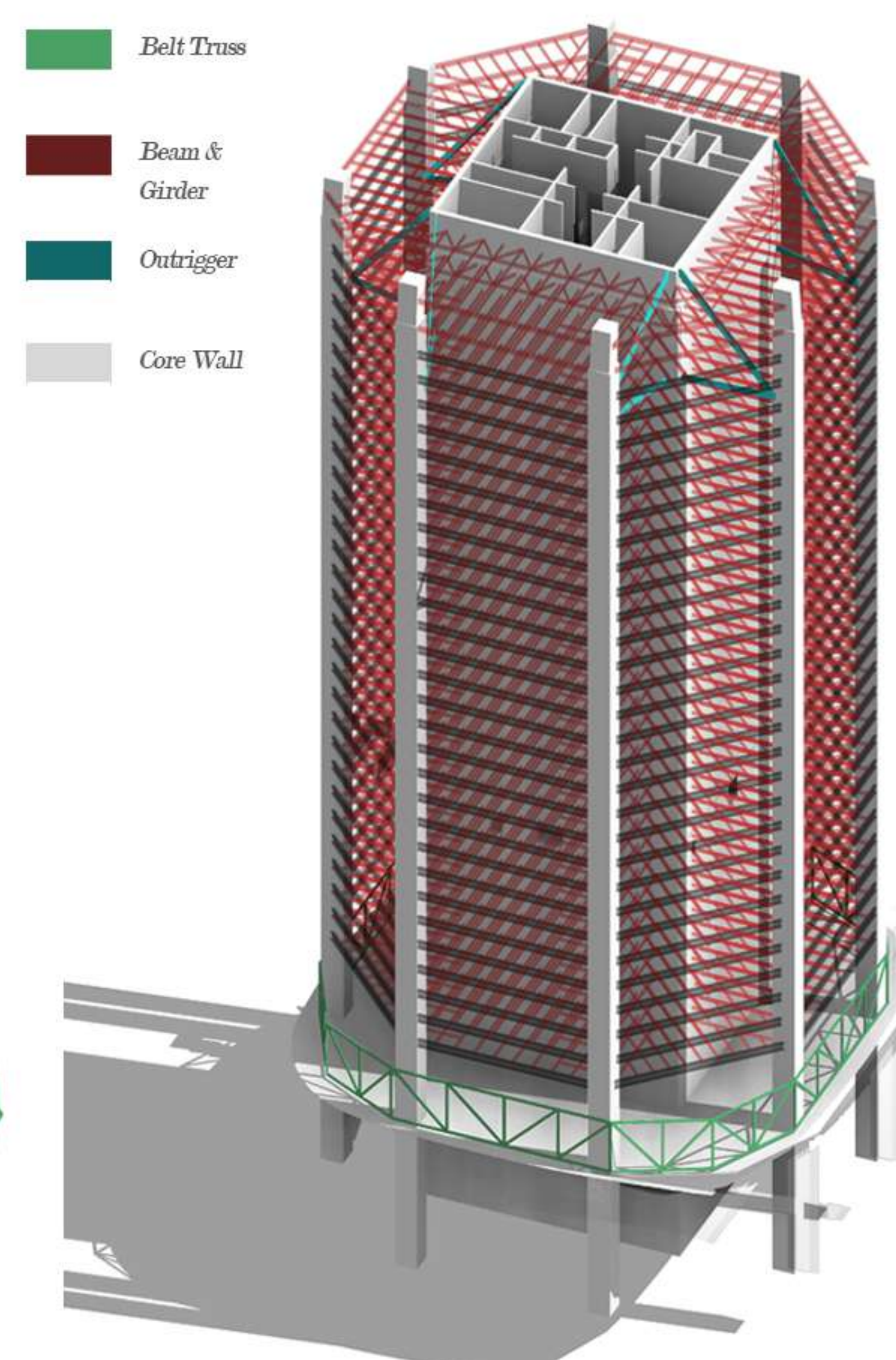

SECTOR 3 : Belt Truss & Outrigger Structure

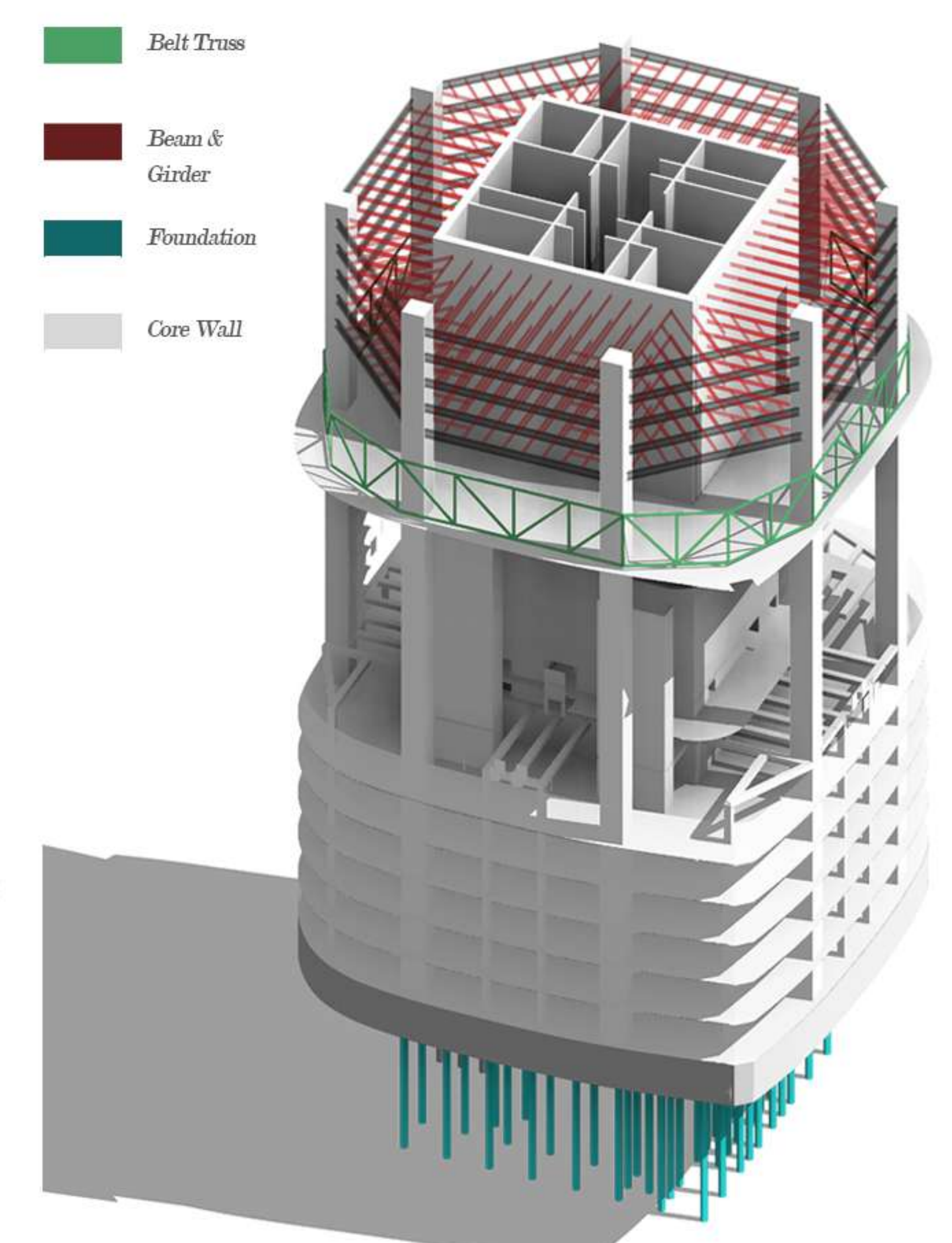

SECTOR 4 : Foundation Structure

Whole Revit Modeling

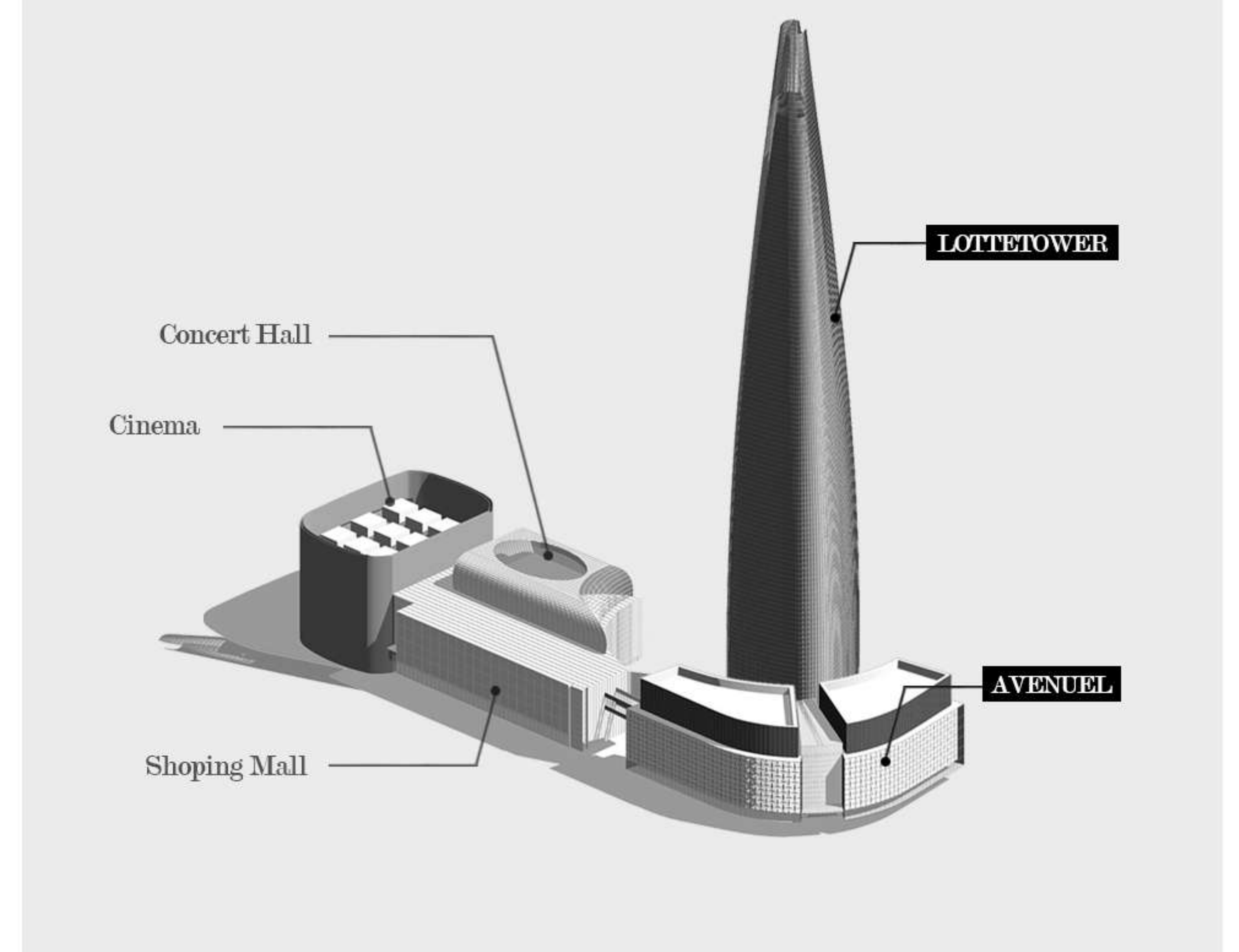

Structure Type Visualization